



SMART HOME SYSTEM

we make things smarter
than it's ever been possible



CATALOGUE

www.larnitech.com

CONTENTS

About Us	3
Useful links	4
Our advantages.....	5
Larnitech Smart Home System Architecture.....	6
Metafora – DE-MG comparison	10
Safety requirements	12
DIN-rail equipment	13
DE-MG.plus	14
DE-MG	15
DE-MG.dali	16
DE-MG.knx	17
Metafora 3 / 3.plus	18
DE-GW	19
DW-LC18.....	20
DW-LC07	21
DW-RC12	22
DW-HT07	23
DW-HT05.....	24
DW-DM06.....	25
DW-DM04.....	26
DW-DM02.....	27
DW-HC10	28
DW-RGB03	29
DW-BC03.....	30
DW-WL02	31
DW-IO	32
DW-SW16.....	33
DW-RS485.....	34
DW-RS232	35
DW-UART.....	36
DW-010.....	37
DW-DALI	38



Pattress box equipment.....	39
BW-LC02	40
BW-DM	41
BW-AC	42
BW-RGB.....	43
BW-SW06	44
BW-SW24V	45
BW-LSA	46
BW-IO	47
BW-NA.....	48
BW-RS485	49
BW-RS232	50
BW-UART.....	51
BW-010.....	52
BT-CAN.....	53
Sensors	54
CW-AIR / CW-AIR(black) / CW-HTMLI-III	55
CW-M-II / CW-M-II (black) / CW-MLI-II	56
CW-MLI / CW-M	57
CW-MSD	58
WW-HTL	59
WW-TS	60
FW-TS	61
FW-FT	62
EW-WL	63
FW-WL	64
FW-WLM / FW-WLM(black).....	65
WW-WL	66
BT-HT	67
Multiroom	68
FE-MP	69
FE-IC.nfc	70
LCP10	71
LCP4	72
Other equipment	73
WW-TERM	74
WW-BTN	75
LED-DRV	76
LED-AMP	77

[TO CONTENTS](#)



ABOUT US

Larnitech is a developer and manufacturer of ‘Smart Home’ systems for home and office automation. The head office of the company is located in Frondenberg (Germany).

Our new product line combines easy mounting and installation with a wide range of the system functional features. The use of modern elements allows us to create compact and economical devices.

Our team of designers and software developers has created user-friendly software for managing the system, which allows our clients to manage the most sophisticated tasks.

The modern world is experiencing an unprecedented boost in the sphere of IT. We, at Larnitech, are fully aware of this trend and are doing everything in our power to provide our own share of innovations in the field of smart house technology. We strive to become a leader in our market niche. Through our high-tech environment-friendly products, we contribute to saving the world’s natural resources and fulfil our mission of developing modern housing that combines progressive ideas, comfort and safety.

[TO CONTENTS](#)



USEFUL LINKS

WEBSITE: larnitech.com



CATALOGUE: larnitech.com/catalogue/



WIKI: wiki.larnitech.com



EDUCATION CENTER: ec.larnitech.com



 **YOUTUBE**
[@LarnitechDeutschland](https://www.youtube.com/@LarnitechDeutschland)



 **FACEBOOK**
[@larnitech](https://www.facebook.com/larnitech)



 **INSTAGRAM**
[@larnitech](https://www.instagram.com/larnitech)



 **SUPPORT**
support@larnitech.com



TO CONTENTS



OUR ADVANTAGES

- Really quick and easy equipment setup with true Plug&Play technology
- The basic setup of the system is done from a tablet and does not require special coding skills
- Reliable support service, which responds to any queries fast
- Great conditions for cooperation
- Training provided
- Numerous ready-made scenarios (that enable the creation of a home that's truly smart)
- Voice control (Alexa, Siri and Google Home integrated)
- Free software for iOS, Android, Windows, Mac, Linux
- Remote control from any point of the world (Using cloud connection)
- German quality
- Integration with Philips Hue, IKEA, Sonos, Satel, Dynalite, IFTTT, IntesisBox, CoolMaster and many others
- The multiroom system is fully integrated into the Smart Home system (it is used in scenarios, voice announcements, 'following' sound and others)
- Distributed logic with flexible architecture (there is no 'central element', increased reliability, varying scope of the project, connection of up to 1000 devices)
- A wide range of equipment on offer allows to control all systems of a building
- Intuitive interface for creating scripts using visual language Blockly, programming skills are not required

[TO CONTENTS](#)



LARNITECH SMART HOME SYSTEM ARCHITECTURE

CAN bus, short for Controller Area Network, was developed by a German company Bosch. Due to its reliability, it is widely used in such spheres as car building and aviation. We use CAN bus to exchange information between our modules so that they can work together. The length of the bus can reach 800 meters with up to 50 modules connected to it. All modules are equal and the bus does not have a central node or controller. The bus has 4 wires, with 2 wires used to transmit 24-volt power and two others used to transmit data. Every module in the system has an inbuilt logical controller, which allows for the logic of any complexity to be implemented.

The Main Gateway is also an element of the bus and can be connected to it anywhere. Depending on the model, the Main Gateway can be connected to one or two CAN bus. If it is connected to two of them, it ensures the information flow between the two CAN bus. The Main Gateway is also connected to the local network, which makes it possible for the app on the smartphone or tablet to display the status of devices and control them.

In order to connect more CAN bus, DE-GW modules are used. Each of them is connected to a local network and ensures that 2 extra CAN bus are connected. This way, up to 1000 modules can be connected into one system.

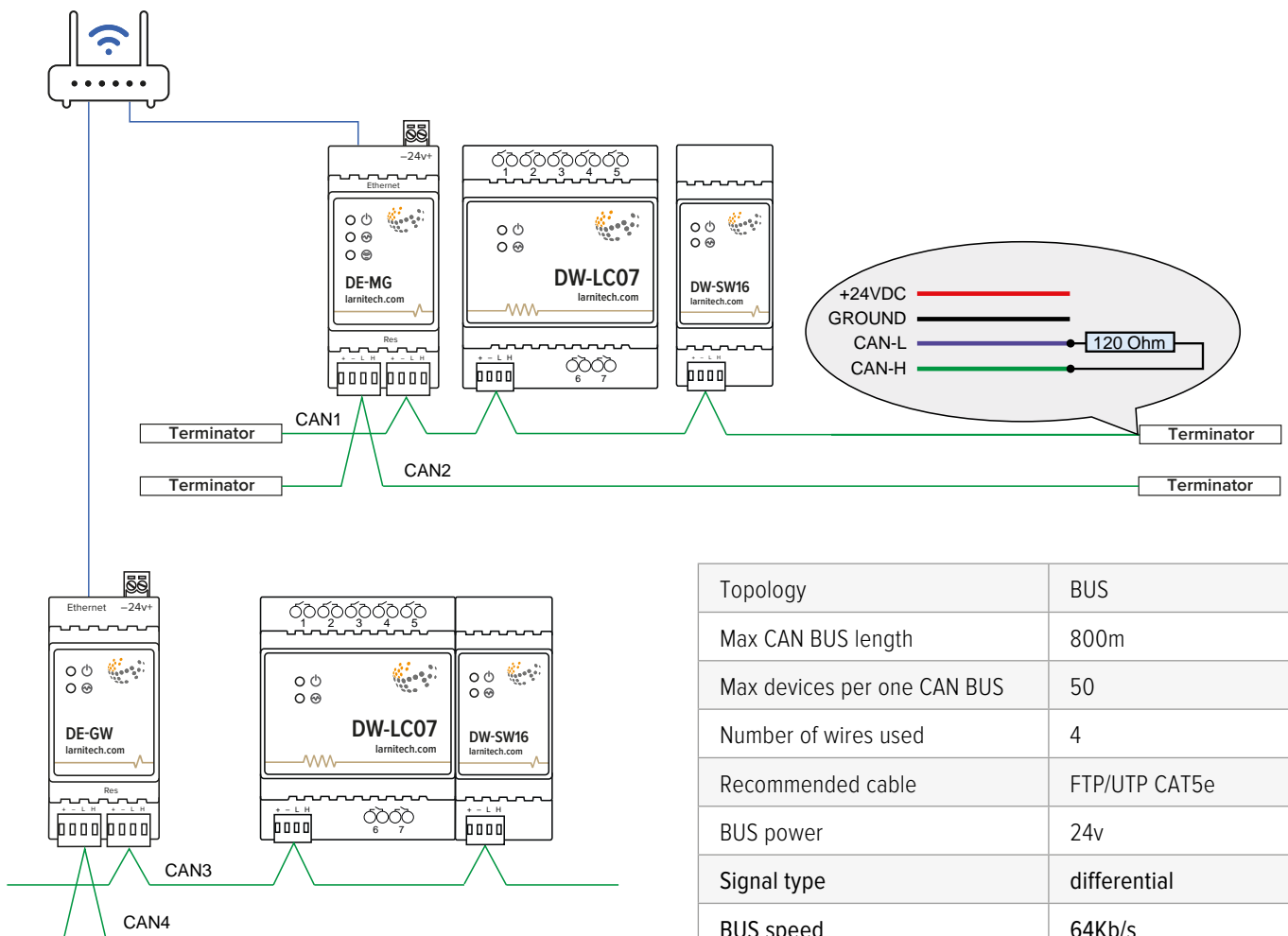

Topology	BUS
Max CAN BUS length	800m
Max devices per one CAN BUS	50
Number of wires used	4
Recommended cable	FTP/UTP CAT5e
BUS power	24v
Signal type	differential
BUS speed	64Kb/s
Terminator type	Resistance 120Ohm

* installing additional power supply units is required for long lines, the maximum length of the line may be reduced by various interference factors

Media Points of the Multiroom system, intercom, cameras and other devices can also be integrated into the system via a local network. We have designed our system to be flexible, reliable, functional and easily scalable.

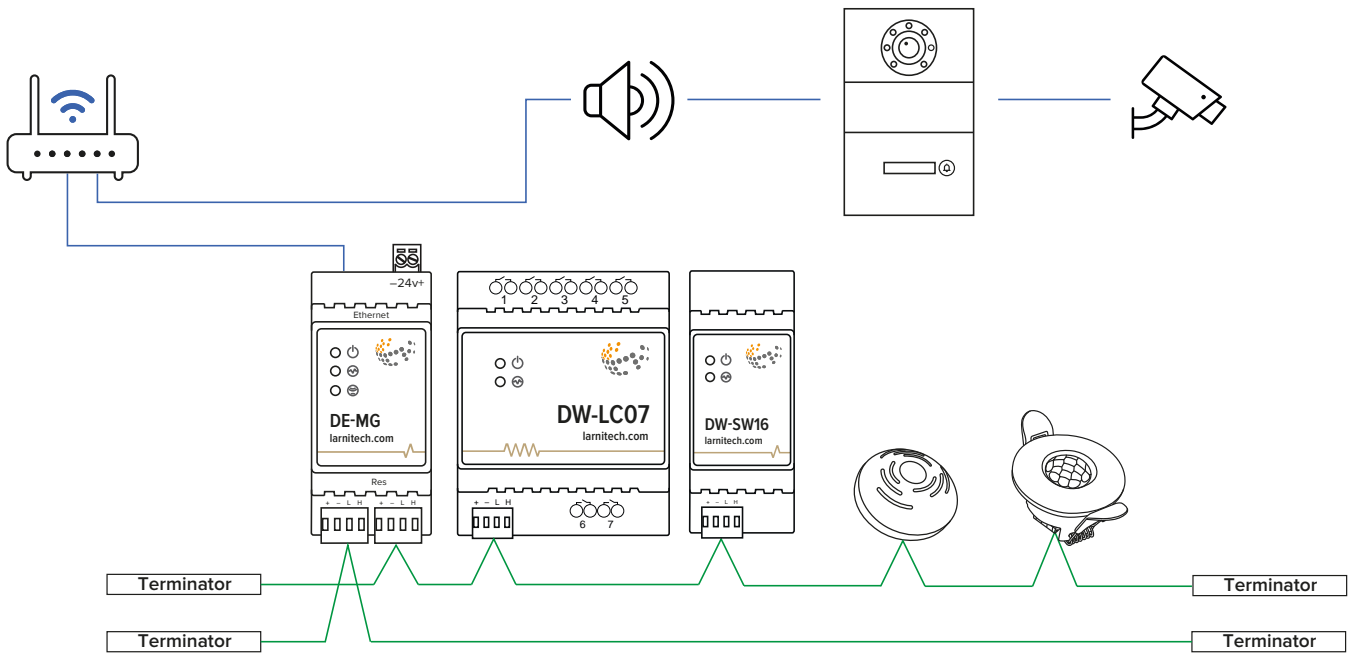

The climate control system includes controlling heating, cooling, warm floors, air humidification and ventilation. For this, control drives for radiators, fan coils, AC units, warm floor and ventilation are connected to the system.

Based on the schedule and meter data, the system maintains the set climatic parameters in every part of the house.



The Multiroom system is also built on the principle of distributed logic and has no central element. Every Media Point is independent and interacts with the whole system.

The Media Point can receive and implement tasks coming from scenarios, buttons or the application. For example, when a water leakage is discovered with the leakage sensor, all media points will receive the command to play a message about it. With a push of a button, the volume level will be changed or the next track will be played.

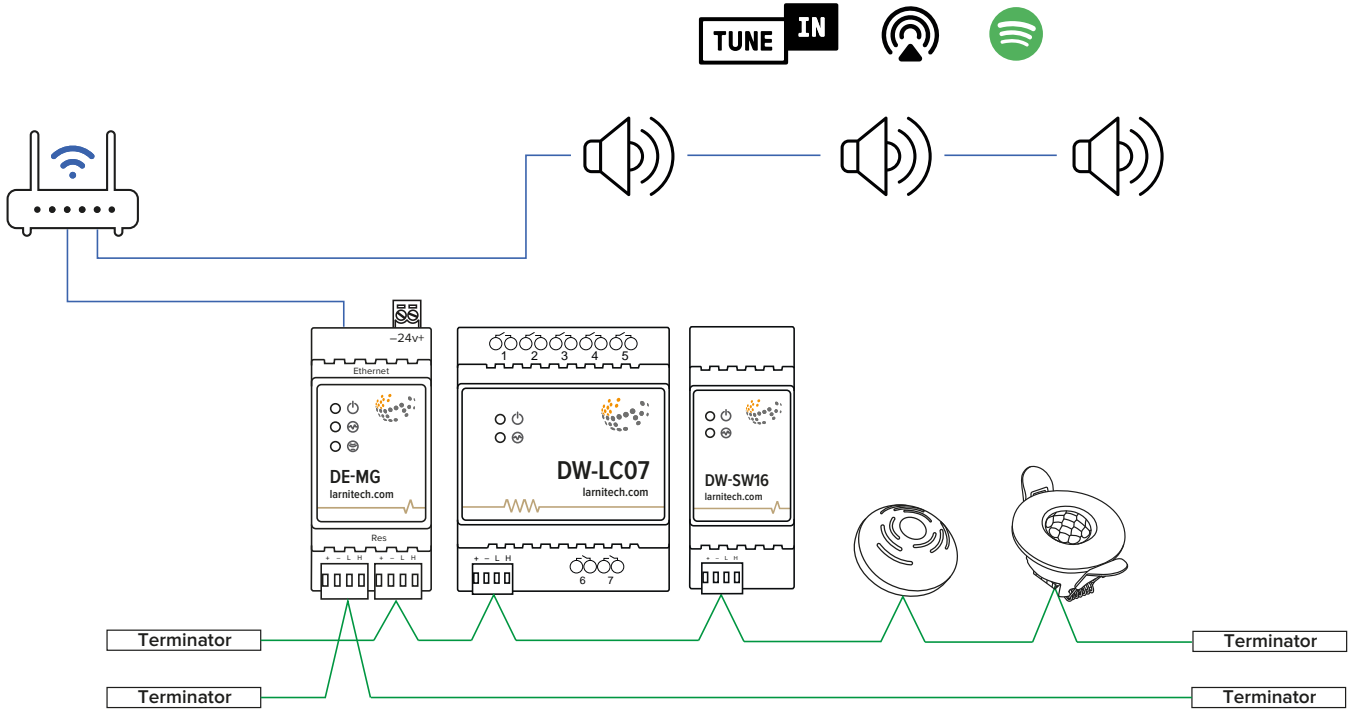

In order to integrate other devices into the system, universal interface modules can be used (RS485, RS232, UART, 0-10V). With the help of the BW-IO module, some devices initially not meant for any integration can still be integrated, for instance some models of coffee makers, extraction units and others.

Our system supports integration with voice assistants such as Siri, Alexa and Google Assistant out of the box.

One of the functions of the basic unit is keeping track of statistical data of all sensors and actuators. The data is stored for a year and can be viewed on a mobile device at any moment.

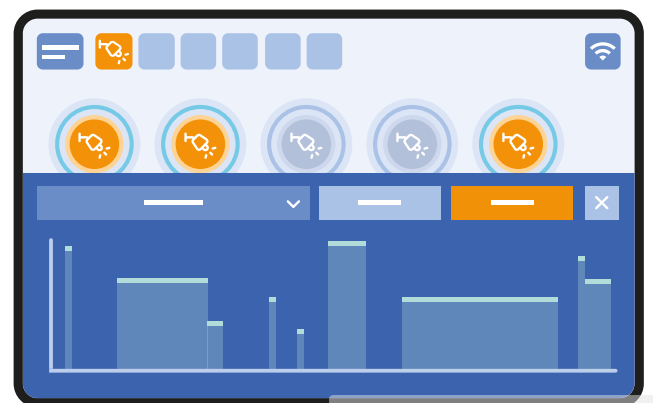

[TO CONTENTS](#)

The Main Gateway is responsible for the configuration of modules in the system. For example, after a user sets up the automation settings or binding buttons, the corresponding settings of logical units are sent to modules, after which they operate according to the pre-programmed configuration.

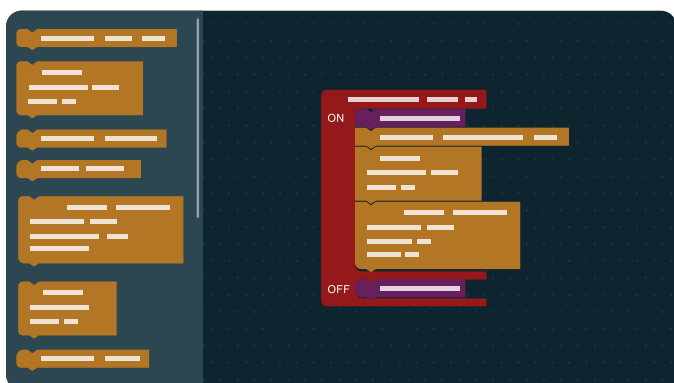

The Main Gateway also contains the database of ready-made scenarios, which – once they have been added - are sent to the modules for implementation. For example, the ‘I’m gone’ scenario can turn off all the lighting and music, put the climate control systems into energy saving mode, via the Multiroom system notify the household about an unlocked back door, turn on the security system and, if it’s dark outside, keep the outside lights on for several minutes while the house owners are leaving the property. One can also create their own scenarios in the graphic editor from ready-made blocks.

One of the basic functions making the setting up of the system significantly easier is Plug&Play. After connecting a new module, it sends the information about itself and the devices it is responsible for to the Main Gateway, which automatically adds the new module to the system and informs the application about the newly added modules and devices.

Just a few seconds after connecting, the newly-added devices appear on the smartphone screen and are ready to be used. After this they can be renamed or moved to another area directly in the application.

For convenience and more advanced setup of the system, you can use a web panel LTSetup, which is available in every Main Gateway. The LTSetup panel can also be accessed from the dealer administrator panel. The system configuration can be set up or changed remotely, without being physically present at the site.

The Larnitech system has the following key advantages:

- High reliability due to distributed logic and in-built logical units in every module;
- Plug&Play system, which significantly speeds up and simplifies the setting up of the system;
- Convenient application for iOS, Android, Windows, Mac, Linux, which allows for basic setting up of the system;
- A database of ready-made scenarios and the possibility to implement the client’s own scenarios of any complexity;
- Fast cloud services ‘out of the box’ without extra settings;
- Voice assistants ‘out of the box’, which don’t require any special hardware;
- A smart climate control system;
- Integrated multiroom system and the intercom with remote control;
- Wide possibilities to integrate various devices and services;
- Keeping device and sensor statistics for a year.

[TO CONTENTS](#)

METAFORSA – DE-MG COMPARISON

Larnitech GmbH offers smart home systems of two varieties: the simplified basic system called MetaforSA and the full-function Larnitech Smart Home, based on the DE-MG (main gateway) module. The table below offers the comparison between the 4 options.

Feature	DE-MG	DE-MG.plus	MetaforSA3	MetaforSA3.plus
Quantity of supported extra modules This is the quantity of extra modules that can be connected to the Smart Home system	999	999	4 ¹	99
Lighting scenarios There is a possibility of creating various lighting scenarios	+	+	+	+
Lighting automation Lighting automation is based on motion detectors, level of lighting, door position, time and date	+	+	+	+
Quantity of additional scenarios This is the number of additional scenarios that can be used in the system. Lighting scenarios and lighting automation are considered basic functions and are not included in this list	150+ ²	150+ ²	70+ ²	150+ ²
Quantity of IP cameras that can be integrated into the system This function allows to view the image captured by IP cameras and to control them using the Larnitech Smart Home application	99	99	1	99
Possibility of creating custom scenarios Possibility of creating custom scenarios that do not exist in the database	+	+	— ¹	+
Voice control (Siri, Alexa, Google Home, Alisa)	+	+	+	+
Support of multiroom system Ability to integrate the media points into the Smart Home system in order to play the voice messages and control media content	+	+	+	+
Intercom Possibility to connect the FE-IC intercom to Larnitech Smart Home system	+	+	+	+
Support of third party media devices Possibility to control the third party media devices that support the DLNA protocol	+	+	—	+
Remote control Remote connection that allows to control all Smart Home systems through direct or cloud connection	+	+	+	+

[TO CONTENTS](#)

Feature	DE-MG	DE-MG.plus	Metaforsa3	Metaforsa3.plus
API Application programming interface that allows to exchange data and commands with third party applications	+	+	+	+
Plug & Play Technology that automatically detects and preconfigures new devices connected to the system	+	+	+	+
Video cloud Possibility to view the image from IP cameras with the help of cloud connection	+	+	+	+
Number of relay outputs Quantity of output channels that are built into the module in order to connect the load	–	–	10	10
Number of discrete inputs Quantity of input channels that are built into the module in order to connect the sensors and buttons	–	–	24	24
Number of dimming channels Quantity of dimming channels that are built into the module in order to connect the dimming lamps	–	–	4	4
Number of PWM outputs PWM outputs combined with inputs	–	–	28	28
Number of CAN ports Quantity of CAN ports in order to connect additional modules	2	2	1	1
Built-in IR receiver Infrared receiver used to set up an universal remote	+	+	+	+
Additional interfaces	–	Bluetooth KNX	–	RS485

¹ Can be extended with the license

² Continually expands

[TO CONTENTS](#)

SAFETY REQUIREMENTS

CAUTION! All work related to the installation, connection, setting up, service and support must be carried out by qualified personnel with sufficient skills and experience in working with electrical equipment.

To avoid the risk of fire, electric shock, damage to the system and / or personal injury, the system installation and assembly must be performed in accordance with the instructions listed below:

- all connection work must be carried out without power;
- use appropriate tools and personal protection against electric shock;
- do not use damaged cables, wires and connectors;
- avoid folding cables and wires;
- do not pinch or kink the cables and wires by applying excessive force. Otherwise, inner conductors of the cables and wires may be stripped or broken;
- do not use the power socket with poor contacts to connect;
- do not exceed the load limit parameters specified in this manual;
- the supply conductors wire section is subject to the specifications for current density limit, insulation type and wire material. Light section can result in cable overheating and fire.

When working with the system after voltage supply NEVER:

- connect/disconnect the connectors;
- open modules and sensors.

[TO CONTENTS](#)



DIN-RAIL EQUIPMENT

[TO CONTENTS](#)



DE-MG.plus MAIN GATEWAY



FEATURES

- One DE-MG.plus can manage up to 1000 devices
- Cloud connection and control of all house systems
- 2xCAN, EIB, Bluetooth interfaces
- 4-core processor
- Voice control (Siri, Alexa, Google Home)
- Plugins engine allows expanding the system possibilities (e.g. integrating with Satel, Philips Hue, Somfy, Luxaflex, IKEA)
- Safety against unauthorized intrusion ensured with RSA/AES256 encryption
- Push notifications from the system on your phone (also possible to receive through Telegram and Viber messengers)
- History (meter data for 1 year is stored)
- Plug and play (possibility for fast and user-friendly extension of the system)
- Large constantly updated database of scripts to meet all your needs
- Automatic daily backups via cloud with the possibility to restore the initial configuration
- Open API
- Interactive and user-friendly LT SETUP Web interface available for advanced configuration

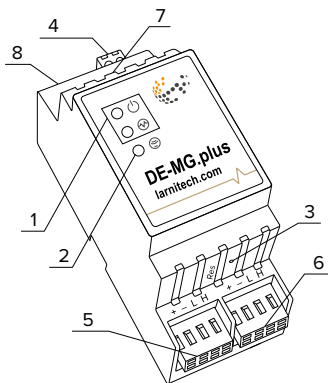

- 1. Indicators
- 2. IR Receiver
- 3. Recovery button
- 4. Power supply
- 5. CAN1
- 6. CAN2
- 7. Ethernet
- 8. EIB

It is used for accumulation and storage of system data. The device determines the logical scheme of the system and allows authorized access to the system via the Internet. It also converts Ethernet into CAN bus, EIB, Bluetooth and vice versa. DE-MG.plus has a built-in IR receiver.

Module parameters

Parameter name	Value
Input/output interfaces	Ethernet, 2xCAN, EIB, Bluetooth
Data speed	10/100Mb/s
Max CAN devices	100(50 per CAN)
CAN bus topology	BUS
Number of CAN ports	2
Power supply	11.5 ... 27.5 V DC 24V, 2.5A Recommended
Max own current (24V)	140mA
Max CAN bus length	800 m* (twisted pair CAT5e)
Max CAN bus current	700mA
IR Receiver angle	30°
Case material	ABS
Protection	IP40
Equipment installation type	DIN-rail (EN 60715)
Temperature range	-10 ... +50°C
Size	2U, 36x102x58 mm
Weight	145 g

* installing additional power supply units is required for long lines; the maximum length of the line may be reduced by various interference factors

Connection example

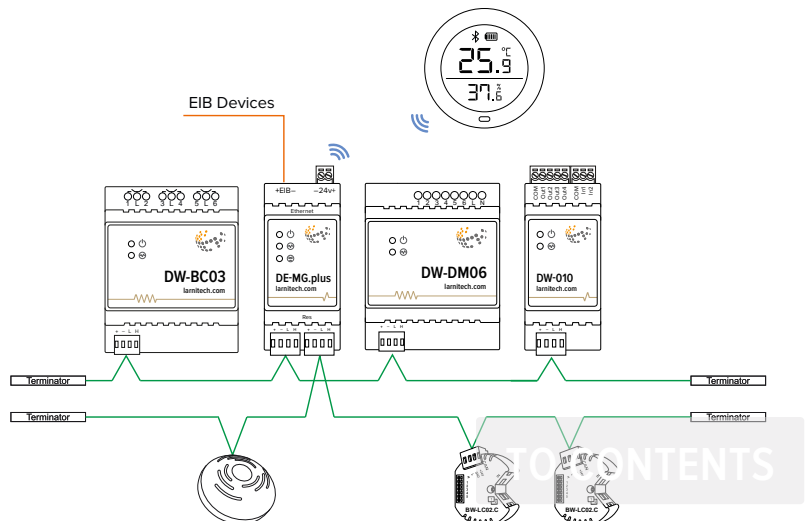

DIN rail equipment

DE-MG MAIN GATEWAY

It is used for accumulation and storage of system data. The device determines the logical scheme of the system and allows authorized access to the system via the Internet. It also converts Ethernet into CAN bus and vice versa. DE-MG has a built-in IR receiver.



FEATURES

- One DE-MG can manage up to 1000 devices
- Cloud connection and control of all house systems
- Voice control (Siri, Alexa, Google Home)
- Plugins engine allows expanding the system possibilities (e.g. integrating with Satel, Philips Hue, Somfy, Luxaflex, IKEA)
- Safety against unauthorized intrusion ensured with RSA/AES256 encryption
- Push notifications from the system on your phone (also possible to receive through Telegram and Viber messengers)
- History (meter data for 1 year is stored)
- Plug and play (possibility for fast and user-friendly extension of the system)
- Large constantly updated database of scripts to meet all your needs
- Automatic daily backups via cloud with the possibility to restore the initial configuration
- Open API
- Interactive and user-friendly LT SETUP Web interface available for advanced configuration

Module parameters

Parameter name	Value
Input/output interfaces	Ethernet, 2xCAN
Data speed	10/100Mb/s
Max CAN devices	100(50 per CAN)
CAN bus topology	BUS
Number of CAN ports	2
Power supply	11.5 ... 27.5 V DC 24V, 2.5A Recommended
Max own current (24V)	140mA
Max CAN bus length	800 m* (twisted pair CAT5e)
Max CAN bus current	700mA
IR Receiver angle	30°
Case material	ABS
Protection	IP40
Equipment installation type	DIN-rail (EN 60715)
Temperature range	-10 ... +50°C
Size	2U, 36x102x58 mm
Weight	145 g

* installing additional power supply units is required for long lines; the maximum length of the line may be reduced by various interference factors

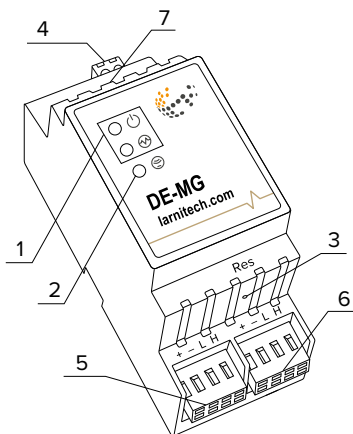

1. Indicators
2. IR Receiver
3. Recovery button
4. Power supply
5. CAN1
6. CAN2
7. Ethernet

Connection example

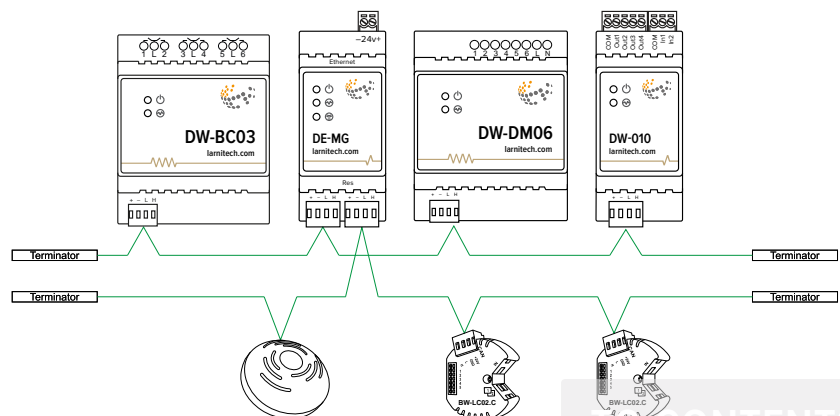

DE-MG.dali MAIN GATEWAY

It is used for accumulation and storage of system data. The device determines the logical scheme of the system and allows authorized access to the system via the Internet. It also converts Ethernet into CAN bus and vice versa.



FEATURES

- One DE-MG can manage up to 1000 devices
- Cloud connection and control of all house systems
- Voice control (Siri, Alexa, Google Home)
- Plugins engine allows expanding the system possibilities (e.g. integrating with Satel, Philips Hue, Somfy, Luxaflex, IKEA)
- Safety against unauthorized intrusion ensured with RSA/AES256, TLS encryption
- Push notifications from the system on your phone (also possible to receive through Telegram and Viber messengers)
- History (meter data for 1 year is stored)
- Plug and play (possibility for fast and user-friendly extension of the system)
- Large constantly updated database of scripts to meet all your needs
- Automatic daily backups via cloud with the possibility to restore the initial configuration
- Open API
- Interactive and user-friendly LT SETUP Web interface available for advanced configuration
- DALI 64 devices

Module parameters

Parameter name	Value
Type of connection	CAN, Ethernet
Input/output interfaces	Ethernet, CAN, DALI, I/O channels
Data speed	10/100Mb/s
Max CAN devices	50
Max DALI devices	64
CAN bus topology	BUS
Number of CAN ports	1
Input/output channels qty	14
Max load per channel	5mA*
Power supply	11.5 ... 27.5 V DC
24V, 2.5A Recommended	140mA
Max own current (24V)	140mA
Max CAN bus length	800 m** (twisted pair CAT5e)
Max current per CAN bus	700mA
Case material	ABS
Protection	IP40
Equipment installation type	DIN-rail (EN 60715)
Temperature range	-10 ... +50°C
Size	4U, 69x110x58 mm
Weight	145 g

Connection example

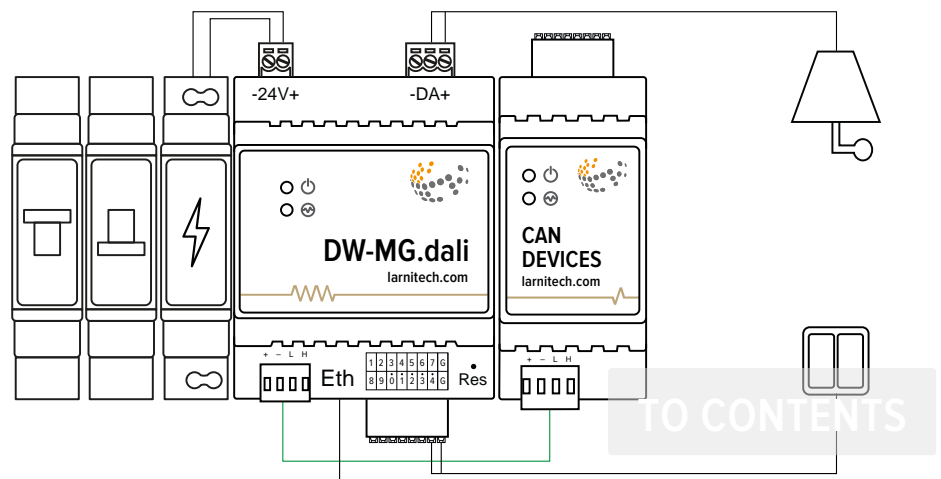

DIN rail equipment

[TO CONTENTS](#)

DE-MG.knx

MAIN GATEWAY

It is used for accumulation and storage of system data. The device determines the logical scheme of the system and allows authorized access to the system via the Internet. It also converts Ethernet into EIB bus and vice versa.



FEATURES

- One DE-MG can manage up to 1000 devices
- Cloud connection and control of all house systems
- Voice control (Siri, Alexa, Google Home)
- Plugins engine allows expanding the system possibilities (e.g. integrating with Satel, Philips Hue, Somfy, Luxaflex, IKEA)
- Safety against unauthorized intrusion ensured with RSA/AES256, TLS encryption
- Push notifications from the system on your phone (also possible to receive through Telegram and Viber messengers)
- History (meter data for 1 year is stored)
- Large constantly updated database of scripts to meet all your needs
- Automatic daily backups via cloud with the possibility to restore the initial configuration
- Open API
- Interactive and user-friendly LT SETUP Web interface available for advanced configuration
- KNX connection

Module parameters

Parameter name	Value
Type of connection	Ethernet
Input/output interfaces	Ethernet, EIB
Data speed	10/100Mb/s
Case material	ABS
Protection	IP40
Equipment installation type	DIN-rail (EN 60715)
Temperature range	-10 ... +50°C
Size	4U, 69x110x58 mm
Weight	145 g

Connection example

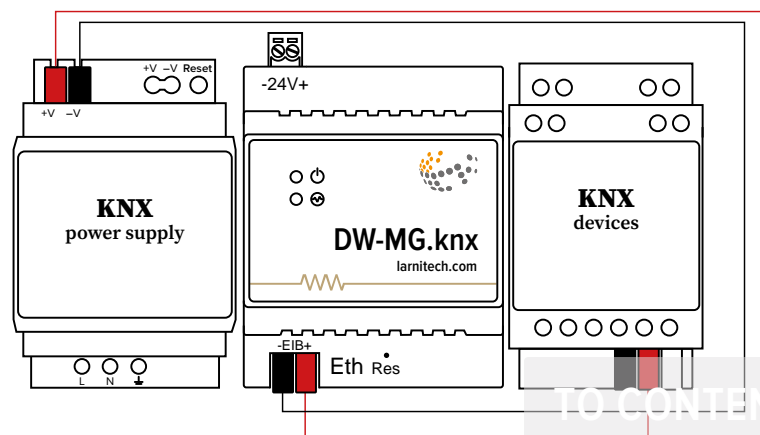

Metaforsa 3 / 3.plus



FEATURES

- **10 universal outputs support:**
 - Lights
 - NC/NO heating valves
 - Blinds
 - 1 or 2-pole gates
 - 1 or 2-pole valves
 - NC/NO locks
 - Fan coil units
- **4 dimming outputs**
- **28 inputs that support:**
 - Buttons
 - LED buttons
 - Switches
 - Reed switches
 - Leak sensors
 - Motion detectors
 - Temperature sensors
 - Led strips
 - 3-4-5 channel rgb strips
 - WS2812B strips
- **Extension port**
- **Relays with AgSnO2 contacts rated for 80A 20ms inrush current**
- **Cloud connection and control of all house systems**
- **Voice control (Siri, Alexa, Google Home)**

It is a completely ready-to-install kit of the Smart Home system. The kit includes the main unit, 3 motion sensors, 2 FW-WL leakage sensors, 4 FW-TS temperature sensors, 4 reed switches, and a PSU.

Module parameters

Parameter name	Value
Switching channels quantity	10
Dimming channels quantity	4
Input channels qty	28
Input voltage	0-250 V
Current type	AC/DC
Max load per channel	16A
Max load per dimming channel	0.5A (110W at 220V)
Power supply	11.5 ... 27.5 V DC
Max current(24V)	0.5 A
BUS type	CAN
Max CAN bus length	800 m* (twisted pair CAT5e)
Max CAN devices	4 (can be extended with the license) 99 (for Metaforsa 3.plus)
Equipment installation type	DIN-rail (EN 60715)
Case material	ABS
Protection	IP40
Temperature range	-10 ... +50 °C
Size	9U, 156x90x58 mm
Weight	400 g

* installing additional power supply units is required for long lines; the maximum length of the line may be reduced by various interference factors

Connection example

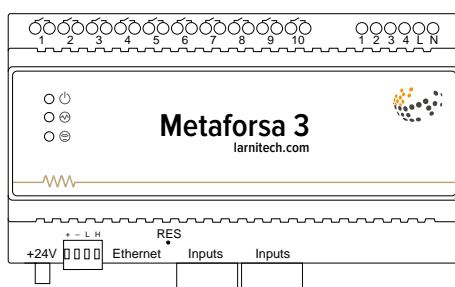
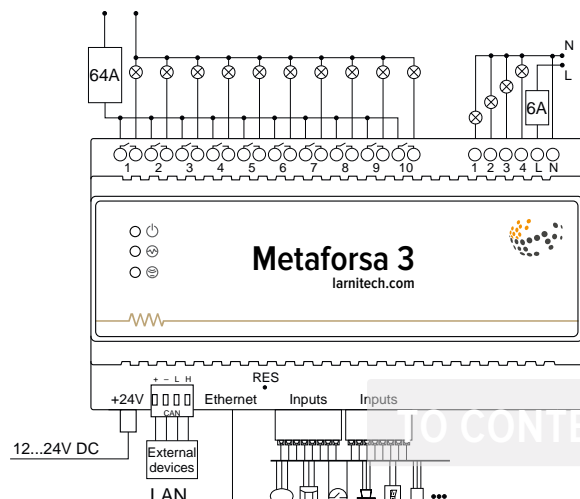

DIN rail equipment

DE-GW GATEWAY

This module is used to connect two additional CAN networks to the system. It also converts Ethernet into CAN bus and vice versa.

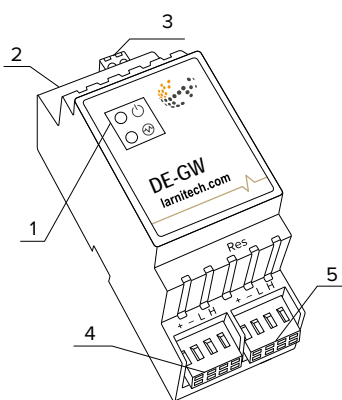

- 1. Indicators
- 2. Ethernet
- 3. Power supply
- 4. CAN1
- 5. CAN2

Module parameters

Parameter name	Value
Type of connection	CAN, Ethernet
Input/output interfaces	Ethernet, 2xCAN
Data speed	10/100Mb/s
Max CAN devices	100(50 per CAN)
CAN bus topology	BUS
Number of CAN ports	2
Power supply	11.5 ... 27.5 V DC 24V, 2.5A Recommended
Max own current (24V)	140mA
Max CAN bus length	800 m* (twisted pair CAT5e)
Max CAN bus current	700mA
Case material	ABS
Protection	IP40
Equipment installation type	DIN-rail (EN 60715)
Temperature range	-10 ... +50°C
Size	2U, 35x95x58 mm
Weight	65 g

* installing additional power supply units is required for long lines; the maximum length of the line may be reduced by various interference factors

Connection example

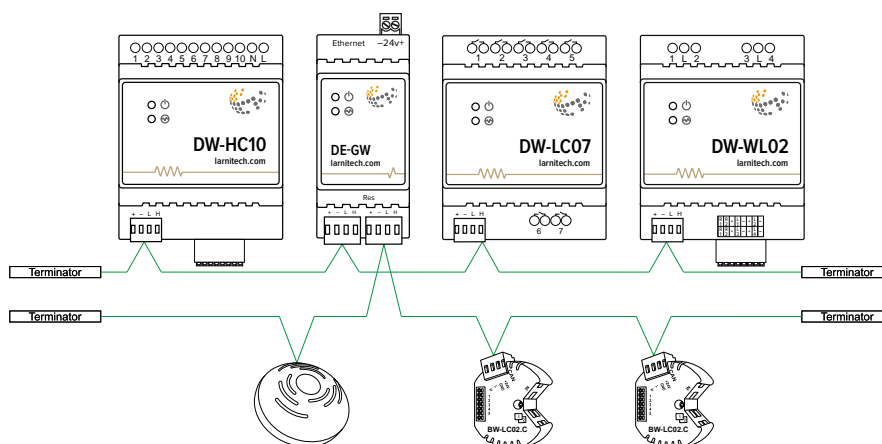

[TO CONTENTS](#)

DW-LC18

18-CHANNEL ACTUATOR



FEATURES

- Control of a wide range of devices:
 - Lights
 - NC/NO heating valves
 - Blinds
 - 1 or 2-pole gates
 - 1 or 2-pole valves
 - NC/NO locks
 - Fan coil units
- Relays with AgSnO2 contacts rated for 16A continuous load and 120A 20ms inrush current
- Low noise relay switching
- Built-in logical unit
- Plug and play feature
- Regular software updates

This module is designed for high power AC/DC circuits commutation. Applicable for light, power sockets, for control of fan coil units, locks, blinds/gates.

Module parameters

Parameter name	Value
Output channels qty	18
Input voltage	0-250V
Current type	AC/DC
Max load per channel	16 A
Power supply	18 ... 27.5 V DC from CAN
Max current(24V)	315 mA
Permissible section of power supply cable to connect in socket:	
single-conductor cable	0.5 ... 4mm ²
multiple-conductor cable	0.5 ... 4mm ²
tipped multiple-conductor cable	0.5 ... 2.5mm ²
Bus type	CAN (4-wire)
Equipment installation type	DIN-rail (EN 60715)
Case material	ABS
Protection	IP40
Temperature range	-10 ... +50 °C
Size	9U, 162x86x60 mm
Weight	475 g

DIN rail equipment

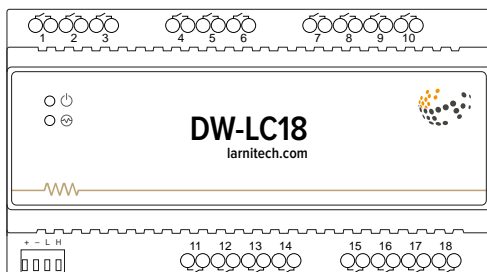

Connection example

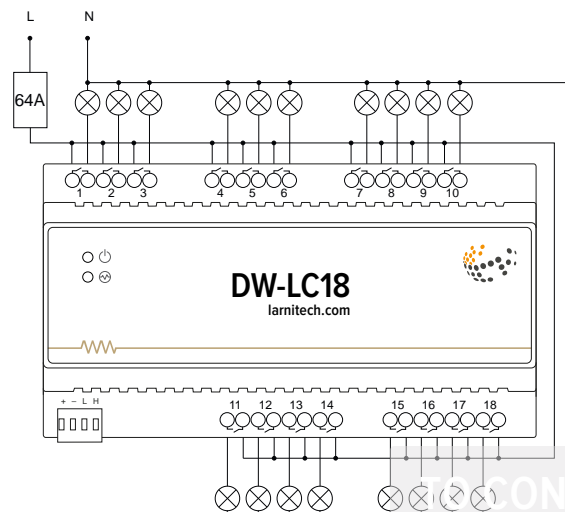

CONTENTS

DW-LC07

7-CHANNEL ACTUATOR



FEATURES

- Control of a wide range of devices:
 - Lights
 - NC/NO heating valves
 - Blinds
 - 1 or 2-pole gates
 - 1 or 2-pole valves
 - NC/NO locks
 - Fan coil units
- Relays with AgSnO2 contacts rated for 16A continuous load and 120A 20ms inrush current
- Low noise relay switching
- Built-in logical unit
- Plug and play feature
- Regular software updates

This module is designed for high power AC/DC circuits commutation. Applicable for light, power sockets, for control of fan coil units, locks, blinds/gates.

Module parameters

Parameter name	Value
Output channels qty	7
Input voltage	0-250V
Current type	AC/DC
Max load per channel	16 A
Power supply	11.5 ... 27.5 V DC from CAN
Max current(24V)	150 mA
Permissible section of power supply cable to connect in socket:	
single-conductor cable	0.5 ... 4mm ²
multiple-conductor cable	0.5 ... 4mm ²
tipped multiple-conductor cable	0.5 ... 2.5mm ²
Bus type	CAN (4-wire)
Equipment installation type	DIN-rail (EN 60715)
Case material	ABS
Protection	IP40
Temperature range	-10 ... +50 °C
Size	4U, 69x115x58 mm
Weight	180 g

Connection example

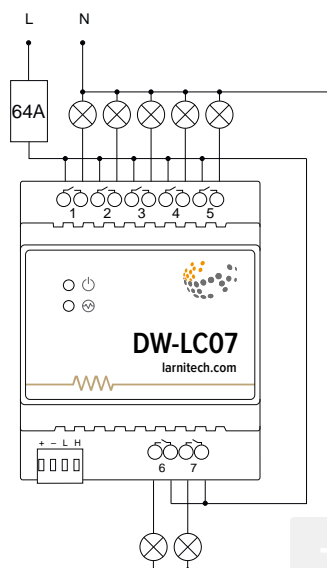
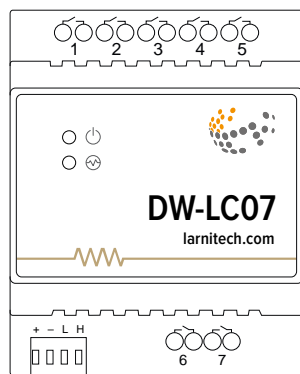

DW-RC12

12-CHANNEL EXTENSION MODULE

This module has 12 outputs for connecting loads and 24 inputs for connecting various sensors/buttons.



FEATURES

- 12 universal outputs support:
 - Lights
 - NC/NO heating valves
 - Blinds
 - 1 or 2-pole gates
 - 1 or 2-pole valves
 - NC/NO locks
 - Fan coil units
- 24 Discreet inputs that support:
 - Buttons
 - Switches
 - Reed switches
 - Leak sensors
 - Motion detectors
- 4 digital inputs for up to 8 temperature sensors

Module parameters

Parameter name	Value
Output channels qty	12
Digital line maximum length	30 m
Discrete input channels qty	24
Digital input channels qty	4
Input voltage	0-250V
Current type	AC/DC
Max load per channel	16A
Power supply	20.0 ... 27.5 V DC from CAN
Max current(24V)	260 mA
Bus type	CAN
Equipment installation type	DIN rail (EN 60715)
Case material	ABS
Protection	IP40
Temperature range	-10 ... +50 °C
Size	9U, 156x110x58 mm
Weight	400 g

Connection example

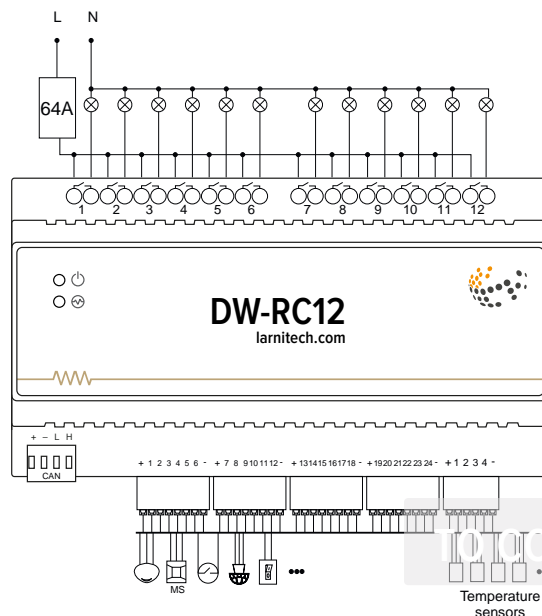

DIN rail equipment

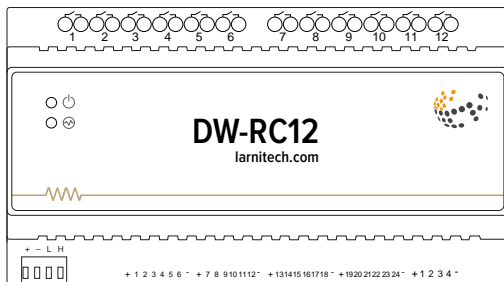

CONTENTS

DW-HT07

7-CHANNEL EXTENSION MODULE

This module has 7 outputs for connecting the load and 12 inputs for connecting various sensors/buttons.



FEATURES

- 7 universal outputs support:
 - Lights
 - NC/NO heating valves
 - Blinds
 - 1 or 2-pole gates
 - 1 or 2-pole valves
 - NC/NO locks
 - Fan coil units
- 12 Discreet inputs that support:
 - Buttons
 - Switches
 - Reed switches
 - Leak sensors
 - Motion detectors
- 4 digital inputs for up to 8 temperature sensors

Module parameters

Parameter name	Value
Output channels qty	7
Discrete input channels qty	12
Digital input channels qty	4 (up to 8 FW-TS sensors)
Input voltage	0-250 V
Current type	AC/DC
Max load per channel	16A
Power supply	11.5 ... 27.5 V DC from CAN
Max current(24V)	140 mA
BUS type	CAN
Equipment installation type	DIN-rail (EN 60715)
Case material	ABS
Protection	IP40
Temperature range	-10 ... +50 °C
Size	4U, 69x115x58 mm
Weight	255 g

Connection example

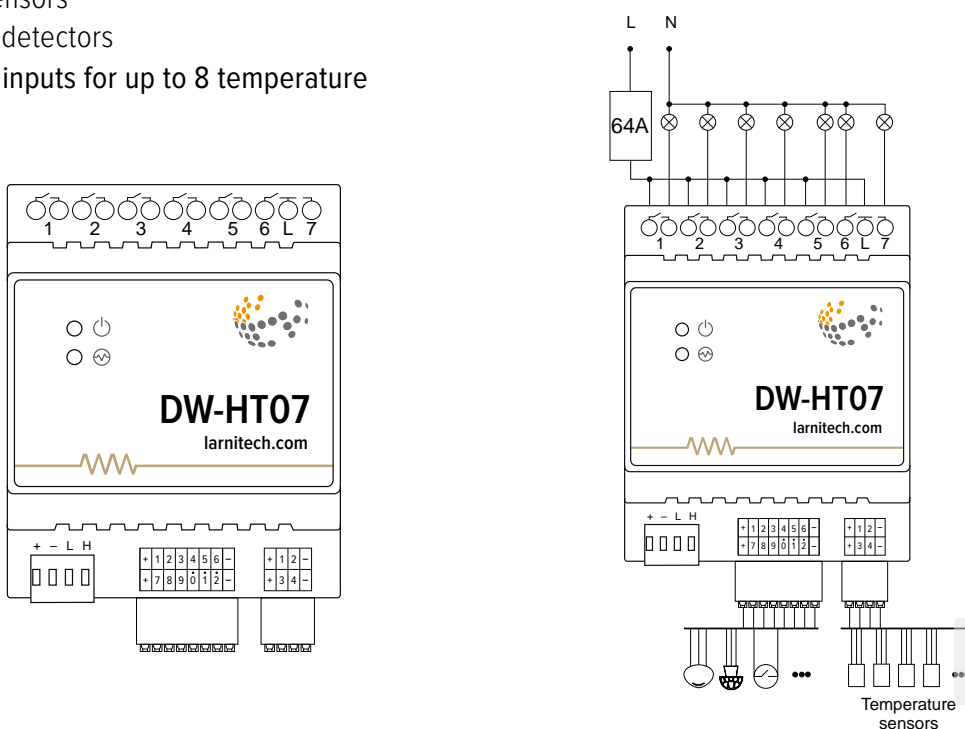

DW-HT05

5-CHANNEL MODULE

Has 5 outputs for connecting load and 12 inputs for connecting various sensors/buttons.



FEATURES

- 5 universal outputs support:
 - Lights
 - NC/NO heating valves
 - Blinds
 - 1 or 2-pole gates
 - 1 or 2-pole valves
 - NC/NO locks
 - Fan coil units
- 12 Discreet inputs that support:
 - Buttons
 - Switches
 - Reed switches
 - Leak sensors
 - Motion detectors

Module parameters

Parameter name	Value
Output channels qty	5
Discrete input channels qty	12
Input voltage	0-250 V
Current type	AC/DC
Max load per channel	16A
Power supply	11.5 ... 27.5 V DC from CAN
Max current(24V)	110 mA
BUS type	CAN
Equipment installation type	DIN-rail (EN 60715)
Case material	ABS
Protection	IP40
Temperature range	-10 ... +50 °C
Size	4U, 69x110x58 mm
Weight	110 g

Connection example

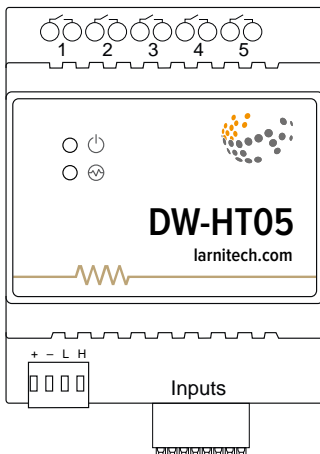
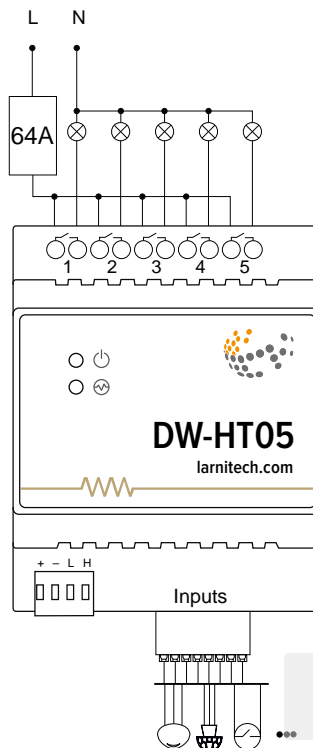

DIN rail equipment

[TO CONTENTS](#)

DW-DM06

6-CHANNEL DIMMER

This module is designed for smooth adjustment of brightness of lighting devices (non reactive load). The dimmer type is MOSFET with trailing edge dimming.



FEATURES

- R/C load type supports (6 x 200 W)
- Works with halogen /LED lights
- Advanced LED light settings
- Soft start mode
- Overload protection
- Overheating protection
- Short-circuit protection
- Plug and play (automatically detected and configured by the system)
- Built-in logical unit
- Regular system updates

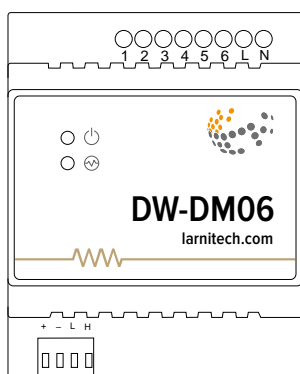

Connection example

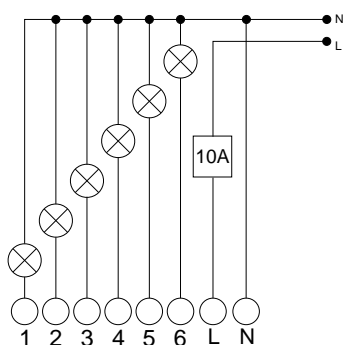

Module parameters

Parameter name	Value
Output channels qty	6
Input voltage	100-240V AC, 50-60 Hz
Current type	AC
Max load per device	5.45A (1200W at 220V)
Max load per channel	0.9A (200W at 220V)
Dimmer type	MOSFET
Dimming type	trailing edge
Power supply	11.5 ... 27.5 V DC from CAN
Max current (24V)	35 mA
Bus type	CAN (4-wire)
Equipment installation type	DIN-rail (EN 60715)
Case material	ABS
Protection	IP40
Temperature range	-10 ... +50 °C
Size	4U, 69x102x58 mm
Weight	180 g

Supported load types

Load type	Value
Conventional incandescent lamps	0-200W
Halogen light sources	0-200W
LED lamps with dimming support	0-200W
Energy saving lamps with dimming support	0-200W
Electronic ballasts with dimming support	0-200W

DW-DM04

4-CHANNEL DIMMER



FEATURES

- R/C load type supports (4 x 500 W)
- Works with halogen /LED lights
- Advanced LED light settings
- Soft start mode
- Overload protection
- Overheating protection
- Short-circuit protection
- Plug and play (automatically detected and configured by the system)
- Built-in logical unit
- Regular system updates

This module is designed for smooth adjustment of brightness of lighting devices (non reactive load). The dimmer type is MOSFET with trailing edge dimming.

Module parameters

Parameter name	Value
Output channels qty	4
Input voltage	100-240V AC, 50-60 Hz
Current type	AC
Max load per device	7.27A (1600W at 220V)
Max load per channel	2.27A (500W at 220V)
Dimmer type	MOSFET
Dimming type	trailing edge
Power supply	11.5 ... 27.5 V DC from CAN
Max current(24V)	35 mA
Bus type	CAN (4-wire)
Equipment installation type	DIN-rail (EN 60715)
Case material	ABS
Protection	IP40
Temperature range	-10 ... +50 °C
Size	4U, 69x102x58 mm
Weight	180 g

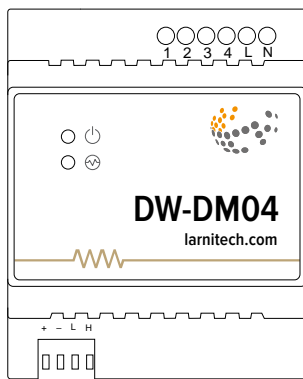

Connection of 4 dimmer lamps

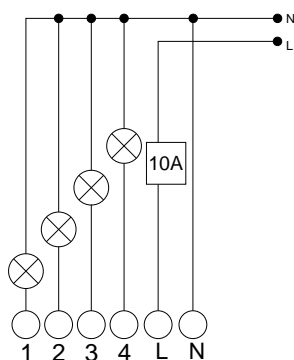

Supported load types

Load type	Value
Conventional incandescent lamps	0-500W
Halogen light sources	0-500W
LED lamps with dimming support	0-500W
Energy saving lamps with dimming support	0-500W
Electronic ballasts with dimming support	0-500W

DIN railequipment

TO CONTENTS

DW-DM02

2-CHANNEL DIMMER

This module is designed for smooth adjustment of brightness of lighting devices (non reactive load). The dimmer type is MOSFET with trailing edge dimming.



FEATURES

- R/C load type supports (2 x 1000 W)
- Works with halogen /LED lights
- Advanced LED light settings
- Soft start mode
- Overload protection
- Overheating protection
- Short-circuit protection
- Plug and play (automatically detected and configured by the system)
- Built-in logical unit
- Regular system updates

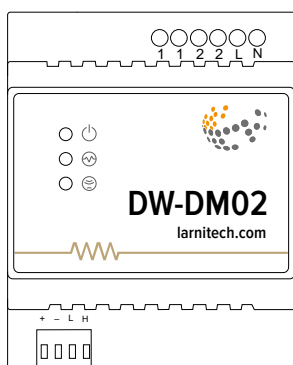

Connection of 2 dimmer lamps

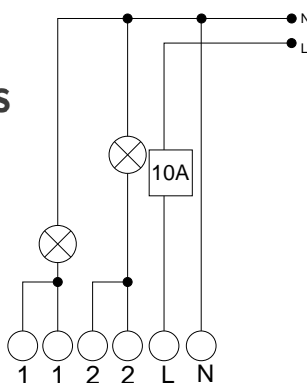

Module parameters

Parameter name	Value
Output channels qty	2
Input voltage	100-240V AC, 50-60 Hz
Current type	AC
Max load per device	7.27A (1600W at 220V)
Max load per channel	4.54A (1000W at 220V)
Dimmer type	MOSFET
Dimming type	trailing edge
Power supply	11.5 ... 27.5 V DC from CAN
Max current(24V)	35 mA
Bus type	CAN (4-wire)
Equipment installation type	DIN-rail (EN 60715)
Case material	ABS
Protection	IP40
Temperature range	-10 ... +50 °C
Size	4U, 69x102x58 mm
Weight	180 g

Supported load types

Load type	Value
Conventional incandescent lamps	0-1000W
Halogen light sources	0-1000W
LED lamps with dimming support	0-1000W
Energy saving lamps with dimming support	0-1000W
Electronic ballasts with dimming support	0-1000W

[TO CONTENTS](#)

DW-HC10

10-CHANNEL HEATING CONTROLLER



FEATURES

- 10 outputs for NO/NC/PWM valves
- 12 inputs for digital and NTC temperature sensors
- Can to use temperature data from other modules
- 10 independent heating zones with weekly schedule
- Up to 20 heating profiles
- Built-in real time clock

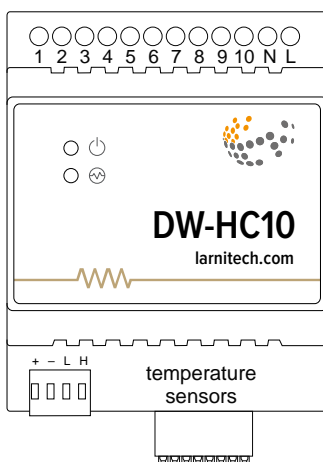

The device is designed for controlling heating devices (radiators, floor heating, fan coil units, etc.). The device is equipped with 12 input channels for connection of temperature sensors.

Module parameters

Parameter name	Value
Output channels qty	10
Input channels qty	12
Load type	NO / NC / PWM (0.4Hz)
Supported sensors	DS18B20 / NTC (7-15kOhm)
Input voltage	20-250 V
Current type	AC/DC
Max load per channel	0.5A(110W at 220V)
Power supply	11.5 ... 27.5 V DC from CAN
Max current(24V)	110 mA
Sensors line max length	30 m
Bus type	CAN (4-wire)
Equipment installation type	DIN-rail (EN 60715)
Case material	ABS
Protection	IP40
Temperature range	-10 ... +50 °C
Size	4U, 69x110x58 mm
Weight	140 g

Connection example

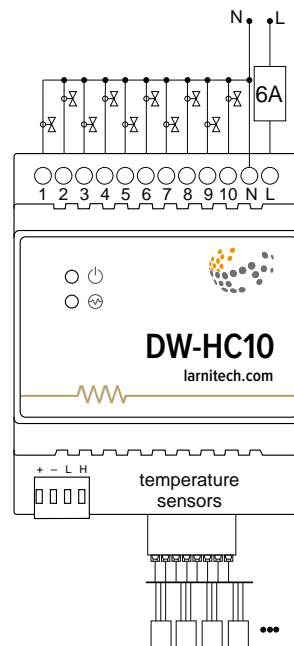

[TO CONTENTS](#)

DW-RGB03

9-CHANNEL LED CONTROLLER

The module allows connecting RGB and monochrome LED strips.



FEATURES

- Supported load types:
 - 3x RGB
 - 2x RGBW + 1 monochrome channels
 - 1x RGBW + 1x RGB or 4x monochrome channels
 - 9x monochrome channels

Module parameters

Parameter name	Value
Output channels qty	9
Input voltage	0 ... 25V DC
Current type	DC
Adjustment type	PWM
Max current (per channel)	3A (36W at 12V)
Power supply	11.5 ... 27.5 V DC from CAN
Max current(24V)	55 mA
Bus type	CAN (4-wire)
Equipment installation type	DIN-rail (EN 60715)
Case material	ABS
Protection	IP40
Temperature range	-10 ... +40 °C
Size	4U, 69x110x58 mm
Weight	85 g

Connection example

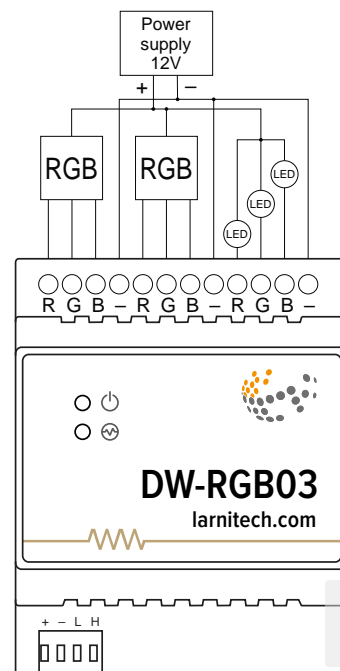
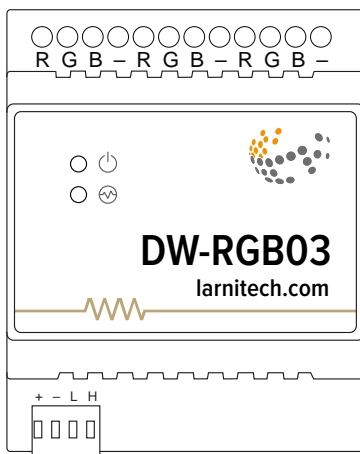

[TO CONTENTS](#)

DW-BC03

3-CHANNEL MODULE FOR BLINDS MOTOR CONTROL



FEATURES

- Supported load types:
 - curtains with force/low-current control
 - 1 / 2 pole valves
- Overcurrent protection
- Built-in current sensor

This module provides control of curtains, projector screens, valves or other electrical motors.

Module parameters

Parameter name	Value
Output channels qty	3
Input voltage	0-250 V AC/DC
Current type	AC/DC
Max load per channel	5 A
Power supply	11.5 ... 27.5 V DC from CAN
Max current(24V)	55 mA
Connection type	CAN
Permissible section of power supply cable to connect in socket: single-conductor cable multiple-conductor cable tipped multiple-conductor cable	0.5 ... 4mm ² 0.5 ... 4mm ² 0.5 ... 2.5mm ²
Bus type	CAN (4-wire)
Equipment installation type	DIN-rail (EN 60715)
Case material	ABS
Protection	IP40
Temperature range	-10 ... +50 °C
Size	4U, 69x110x58 mm
Weight	85 g

DIN rail equipment

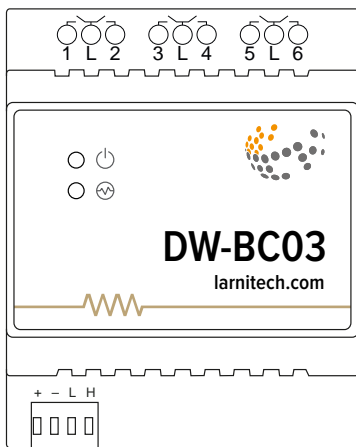

Connection example

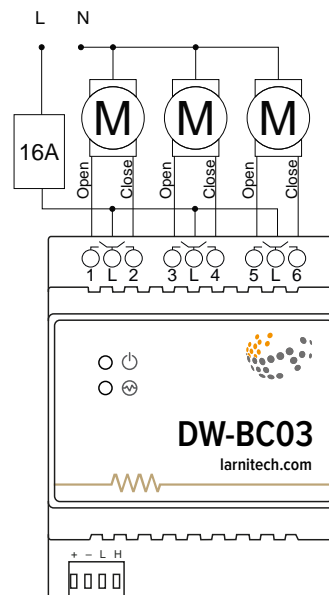

[TO CONTENTS](#)

DW-WL02

WATER LEAKAGE PROTECTION MODULE



FEATURES

- Supports 1p/2p valves
- Valve feedback reed switch
- Support up to 16 leakage sensors
- Sensor detection and diagnostics
- Sensor sensitivity adjustment

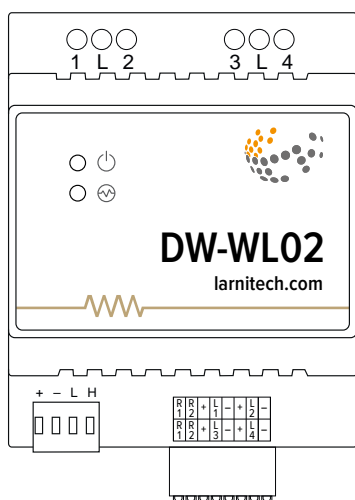

The module supports the connection of 2/4 valves of water supply shutoff and up to 16 leakage sensors.

Module parameters

Parameter name	Value
Output channels qty	4
Number of sensor inputs	4 FW-WL.A/EW-WL.A 16 FW-WL.B/EW-WL.B (4 per input)
Number of dry contact inputs	2
Input voltage	0-250 V AC/DC
Current type	AC/DC
Max load per channel	5 A
Power supply	11.5 ... 27.5 V DC from CAN
Max current(24V)	60 mA
Sensors VCC output	8..12 V
Sensors max VCC current	70 mA
R1-R4 inputs max current	3 mA
Sensor line max length	30m
Bus type	CAN (4-wire)
Equipment installation type	DIN-rail (EN 60715)
Case material	ABS
Protection	IP40
Temperature range	-10 ... +50 °C
Size	4U, 69x110x58 mm
Weight	100 g

Connection of valves and sensors

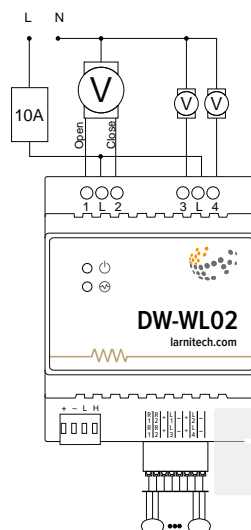

[TO CONTENTS](#)

DW-IO

14-CHANNEL INPUT/OUTPUT ADAPTER



FEATURES

- 14 universal input/output channels support:
 - Buttons
 - Reed switches
 - LED buttons
 - Leak sensors
 - Motion sensors
 - Temperature sensors
 - Led strips
 - 3-4-5 channel rgb strips
 - WS2812B strips

This module can support up to 14 buttons, reed switches, LED buttons, leak sensors, motion sensors, temperature sensors, led strips, rgb strips, WS2812B strips.

Module parameters

Parameter name	Value
Input/output channels qty	14
Backlight voltage	3V
Max load per channel	5mA*
Power supply	11.5 ... 27.5 V DC from CAN
Max current(24V)	30 mA
Push-button/reed switches line recommended length	30m
Bus type	CAN (4-wire)
Equipment installation type	DIN rail (EN 60715)
Case material	ABS
Protection	IP40
Temperature range	-10 ... +50 °C
Size	2U, 36x102x58 mm
Weight	75g

* Output channels should only be connected using amplifier which uses 5V PWM signal from DW-IO output as input

Connector

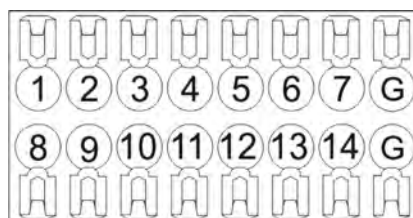

● DIN rail equipment ●

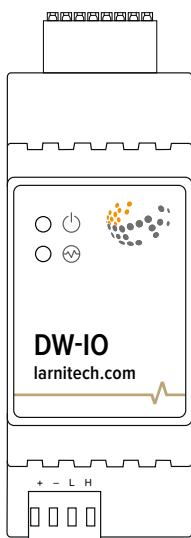

[TO CONTENTS](#)

DW-SW16

16-CHANNEL ADAPTER FOR BUTTONS

This module can support up to 15 buttons/reed switches or 8 LED buttons.



FEATURES

- Up to 15 buttons/reed switches
- Up to 8 LED buttons
- Supports single/double/triple/long click. Up to 4 different actions for each button
- Line noise protection

Module parameters

Parameter name	Value
Input channels qty	16
Buttons	15
LED Buttons	8
Backlight voltage	3V
Power supply	11.5 ... 27.5 V DC from CAN
Max current(24V)	45mA
Bus type	CAN (4-wire)
Equipment installation type	DIN-rail (EN 60715)
Case material	ABS
Protection	IP40
Temperature range	-10 ... +50 °C
Size	2U, 36x102x58 mm
Weight	75g

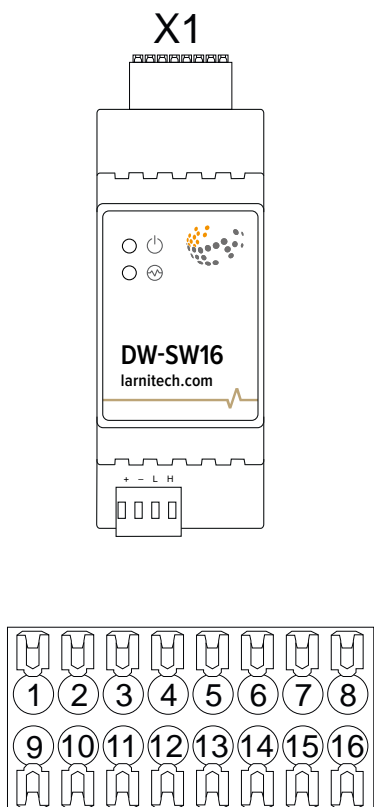

Connection of buttons/LED buttons

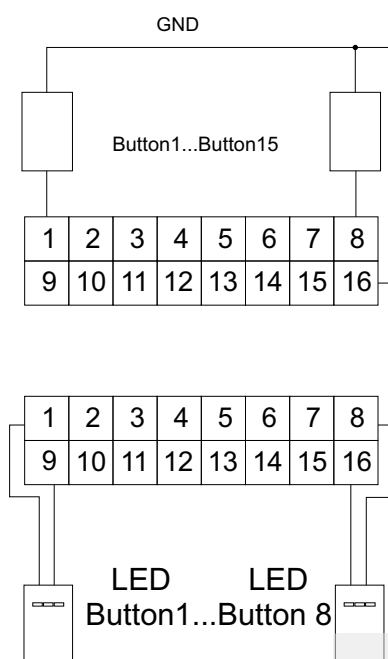

[TO CONTENTS](#)

DW-RS485

RS485 INTERFACE ADAPTER

This module is designed for interface adjustment between the devices which have the RS485 interface and the Smart Home system. This module has an internal 120Ω terminator resistor.



FEATURES

- Supported protocols:
 - ModBus RTU
 - Custom protocols
- 1200 - 115200 baud rate

Module parameters

Parameter name	Value
RS485 ports qty	1
Power supply	11.5 ... 27.5 V DC from CAN
Max current(24V)	40mA
Data transfer speed	1200-115200 b/s
Bus type	CAN (4-wire)
Equipment installation type	DIN-rail (EN 60715)
Case material	ABS
Protection	IP40
Temperature range	-10 ... +50 °C
Size	2U, 36x90x58 mm
Weight	130 g

Connection example

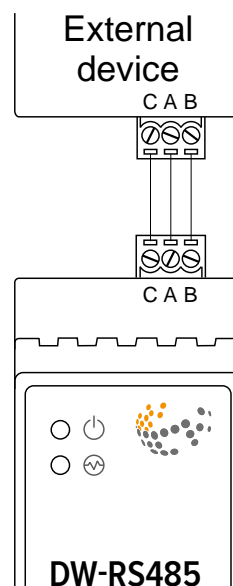
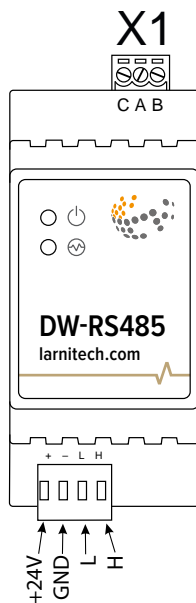

DIN railequipment

[TO CONTENTS](#)

DW-RS232

RS232 INTERFACE ADAPTER

This module is designed for interface adjustment between the devices which have the RS232 interface and the Smart Home system.



Module parameters

Parameter name	Value
RS232 ports qty	1
Power supply	11.5 ... 27.5 V DC from CAN
Max current(24V)	40mA
Data transfer speed	1200-115200 b/s
Bus type	CAN (4-wire)
Equipment installation type	DIN-rail (EN 60715)
Case material	ABS
Protection	IP40
Temperature range	-10 ... +50 °C
Size	2U, 36x90x58 mm
Weight	130 g



Connection example

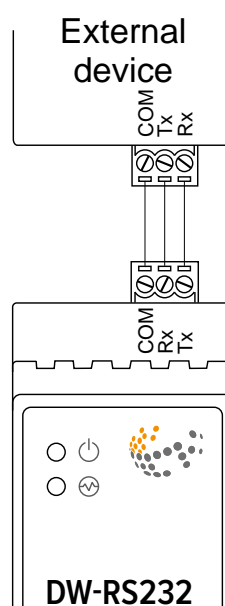

[TO CONTENTS](#)

DW-UART SERIAL INTERFACE ADAPTER

This module is designed for interface adjustment between the devices which have the UART interface (TTL levels) and the Smart Home system.

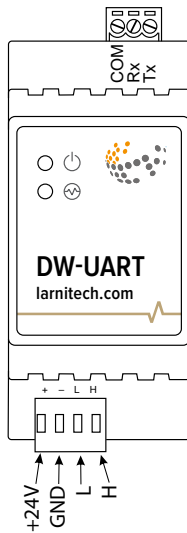

Module parameters

Parameter name	Value
UART ports qty	1
Power supply	11.5 ... 27.5 V DC from CAN
Max current(24V)	40mA
Data transfer speed	1200-115200 b/s
Bus type	CAN (4-wire)
Equipment installation type	DIN-rail (EN 60715)
Case material	ABS
Protection	IP40
Temperature range	-10 ... +50 °C
Size	2U, 36x97x58 mm
Weight	130 g

Connection example

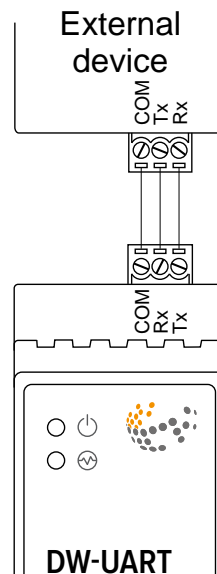

[TO CONTENTS](#)

DW-010

4-CHANNEL MODULE FOR DEVICES WITH 0-10V INPUT

This module allows connecting devices with 0-10V inputs and outputs to the Smart Home system.



FEATURES

- 4x 0-10V outputs
- 2x 0-10V inputs

Module parameters

Parameter name	Value
Input channels qty	2
Output channels quantity	4
Max load per channel	15mA
Power supply	11.5 ... 27.5 V DC from CAN
Max current(24V)	50mA
Bus type	CAN (4-wire)
Equipment installation type	DIN-rail (EN 60715)
Case material	ABS
Protection	IP40
Temperature range	-10 ... +50 °C
Size	2U, 36x97x58 mm
Weight	130 g

Connection example

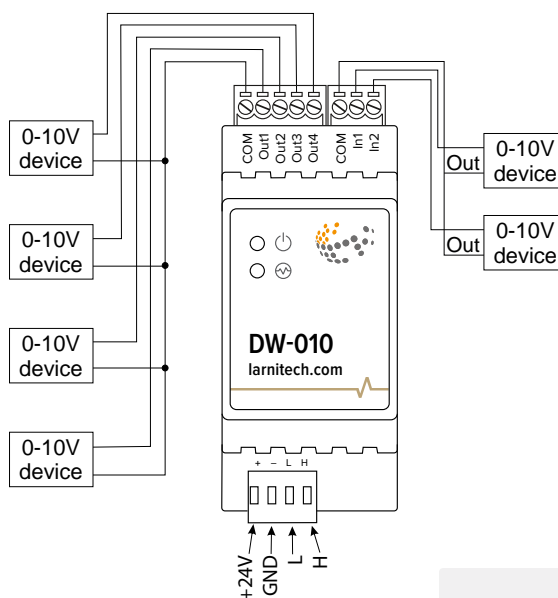
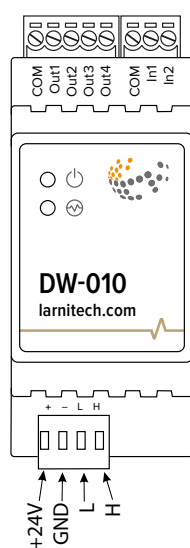

[TO CONTENTS](#)

DW-DALI

2-CHANNEL DALI INTERFACE ADAPTER

This is the module needed to connect the lamp drivers that are controlled with the help of DALI protocol.



FEATURES

- Automatic line scanning for new devices
- Built-in bus power injection
- Dali device configuration

Module parameters

Parameter name	Value
DALI ports qty	2
DALI-line voltage supply	10.5 – 22.5 V DC
Supported DALI protocols	DT6, DT8
Max number of DALI devices	2x 40*
Peak current of DALI-line power supply	1A
Peak current in DALI-line	300 mA
Power supply	11.5 ... 27.5 V DC from CAN
Max current(24V)	30 mA
BUS type	CAN (4-wire)
Equipment installation type	DIN-rail (EN 60715)
Case material	ABS
Protection	IP40
Temperature range	-10 ... +50 °C
Size	2U, 35x97x58 mm
Weight	75 g

* subject to compliance with other parameters

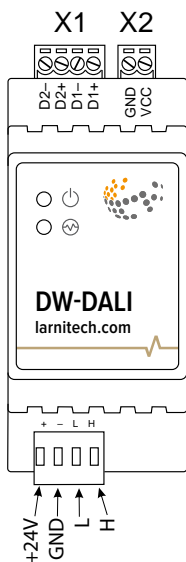

Connection example

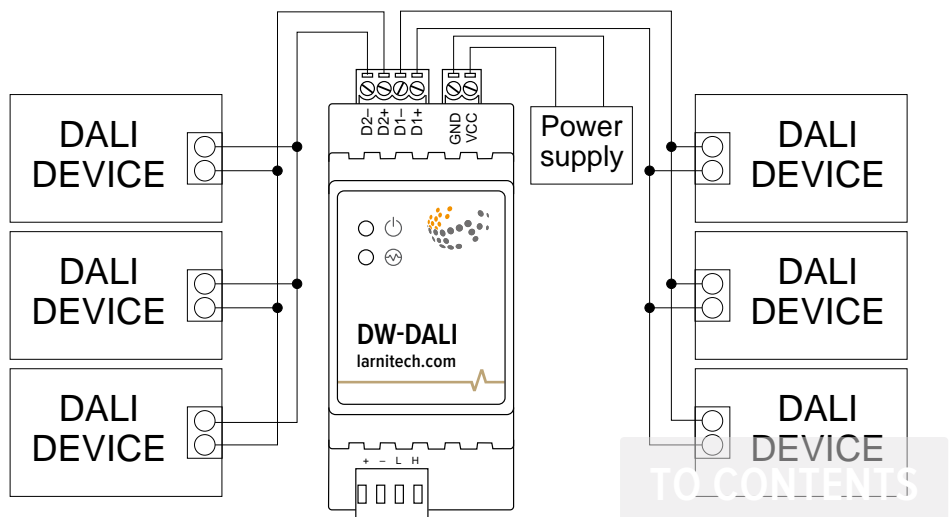

PATTRESS BOX EQUIPMENT

[TO CONTENTS](#)



BW-LC02

2-CHANNEL ACTUATOR

Designed for AC/DC circuits commutation. Applicable for lighting and other electrical devices. It has 6 inputs for connecting buttons and reed switches.



FEATURES

- Compact size (only 16mm thickness)
- 6 inputs support:
 - Buttons
 - Switches
 - Reed switches
 - LED buttons
 - Digital temperature sensor
- Outputs support:
 - Lights
 - NC/NO heating valves
 - NC/NO locks
 - Curtains
 - Projector screens
 - Valves

Module parameters

Parameter name	Value
Output channels qty	2
Input channels qty	6
Buttons	6
LED Buttons	5
Input voltage	0-250 V
Current type	AC/DC
Max load per channel	2 A (440W at 220V)
Backlight voltage	3V
Power supply	11.5 ... 27.5 V DC from CAN
Max current(24V)	35 mA
Permissible section of power supply cable to connect in socket:	
single-conductor cable	0.5 ... 4 mm ²
multiple-conductor cable	0.5 ... 4 mm ²
tipped multiple-conductor cable	0.5 ... 2.5 mm ²
Temperature sensor line max length	10 m
Bus type	CAN (4-wire)
Equipment installation type	Free
Case material	ABS
Protection	IP40
Temperature range	-10 ... +50 °C
Size	45x42x14 mm
Weight	25 g

Connection example

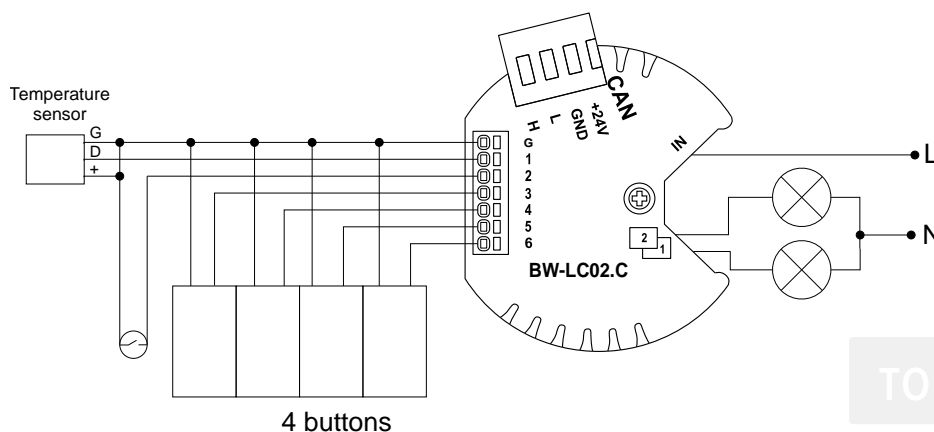

[TO CONTENTS](#)

BW-DM DIMMER





This single-channel dimmer is designed for smooth control of electrical load (non reactive load). It has 3 input channels for connecting buttons and reed switches. MOSFET type.



Module parameters

Parameter name	Value
Output channels qty	1
Input channels qty	3
Input voltage	100-250 V 50Hz
Current type	AC
Max load	0.9A (200W at 220V)
Min load	0.09A (20W at 220V)
Power supply	11.5 ... 27.5 V DC from CAN
Max current(24V)	40 mA
Temperature sensor line max length	0.3 m
Bus type	CAN (4-wire)
Mounting	Free
Case material	ABS
Protection	IP40
Temperature range	-10 ... +50 °C
Size	45x42x14 mm
Weight	25 g

Supported load types

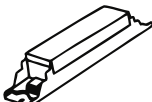
Load type	Value
 Conventional incandescent lamps	20-200W
 Halogen light sources	20-200W
 LED lamps with dimming support	20-200W
 Energy saving lamps with dimming support	20-200W
 Electronic ballasts with dimming support	20-200W

Connection example

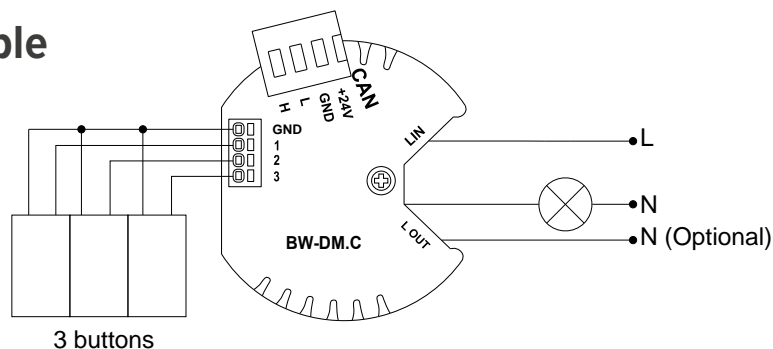

TO CONTENTS

BW-AC AC ADAPTER

This module is designed for integration Mitsubishi AC (connector CN105, CN92), Daikin AC (connector S21) to the Smart Home system.



Module parameters

Parameter name	Value
UART ports qty	1
Power supply	11.5 ... 27.5 V DC from CAN
Max current(24V)	25 mA
Bus type	CAN (4-wire)
Mounting	Free
Case material	ABS
Protection	IP40
Temperature range	-10 ... +50 °C
Size	45x42x14 mm
Weight	15 g

Connection example

● Pattress box equipment ●

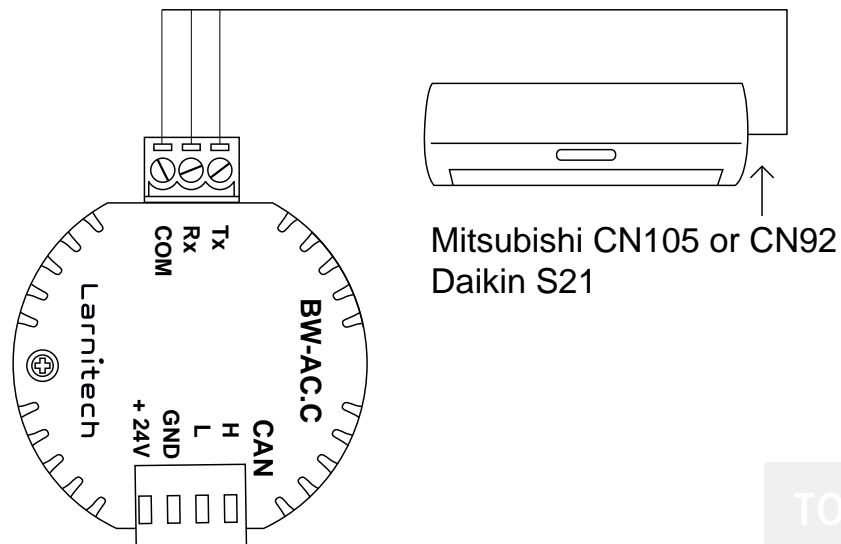

[TO CONTENTS](#)

BW-RGB 3-CHANNEL LED CONTROLLER

This module allows controlling RGB strip or three monochrome LED strips.

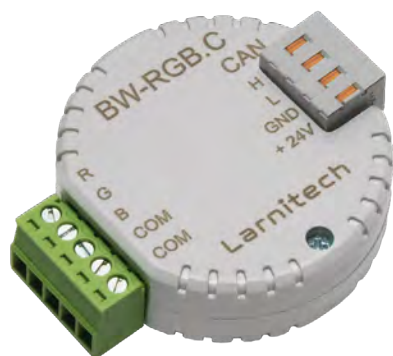

Module parameters

Parameter name	Value
Output channels qty	3
Input voltage	11.5 ... 25V
Current type	DC
Adjustment type	PWM
Max load per channel	1 A (12W at 12V)
Max load power per device	3A (36W at 12V)
Power supply	11.5 ... 27.5 V DC from CAN
Max current(24V)	25 mA
Bus type	CAN (4-wire)
Mounting	Free
Case material	ABS
Protection	IP40
Temperature range	-10 ... +50 °C
Size	45x42x14 mm
Weight	25 g

Connection example

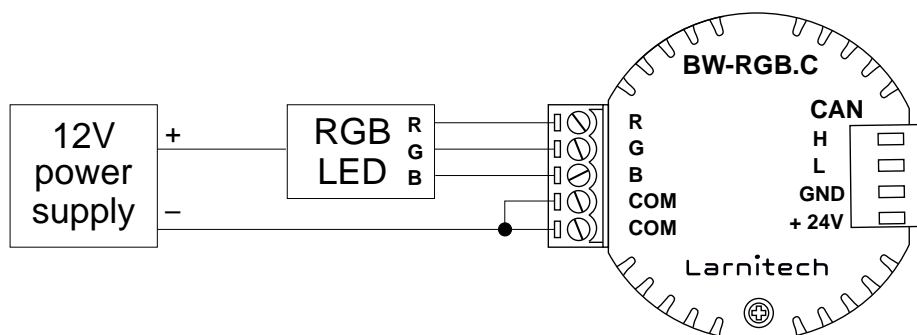

[TO CONTENTS](#)

BW-SW06

6-CHANNEL INPUT MODULE

This module is used to connect buttons/reed switches.



FEATURES

- 6 inputs support:
 - Buttons
 - Switches
 - Reed switches
 - LED buttons
 - Digital temperature sensor

Module parameters

Parameter name	Value
Input channels qty	6
Buttons	6
LED Buttons	5
Backlight voltage	3V
Max current(24V)	30 mA
Power supply	11.5 ... 27.5 V DC from CAN
Temperature sensor line max length	10 m
Bus type	CAN (4-wire)
Mounting	Free
Case material	ABS
Protection	IP40
Temperature range	-10 ... +50 °C
Size	45x42x14 mm
Weight	25 g

Connection example

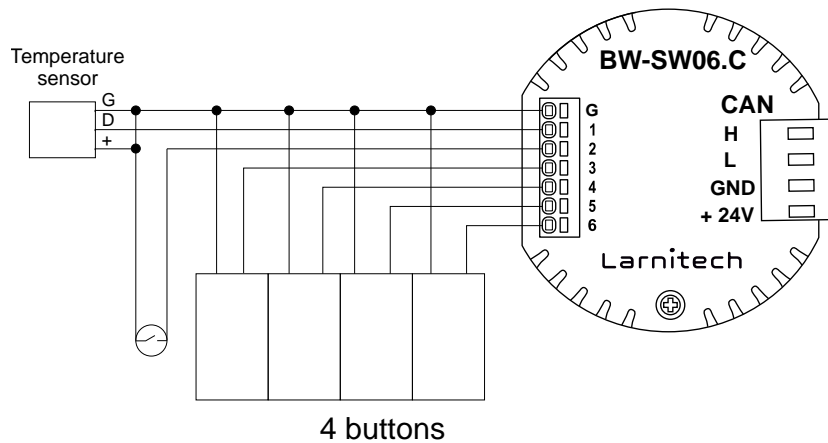

[TO CONTENTS](#)

BW-SW24V

24V BUTTONS INPUT MODULE

This module is used to connect 24V buttons w/wo LED backlighting.



FEATURES

- 6 inputs
- Supports both common anode and cathode LEDs

Module parameters

Parameter name	Value
Output channels qty	6
Input channels qty	6
Buttons	6
LED Buttons	6
Backlight voltage	11.5 ... 27.5 V DC (from CAN)
Max current(24V)	30 mA
Power supply	11.5 ... 27.5 V DC from CAN
Bus type	CAN (4-wire)
Mounting	Free
Case material	ABS
Protection	IP40
Temperature range	-10 ... +50 °C
Size	45x42x14 mm
Weight	25 g

Connection example

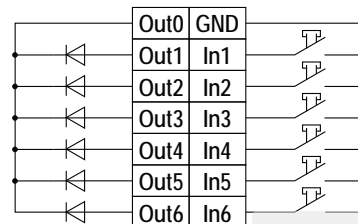
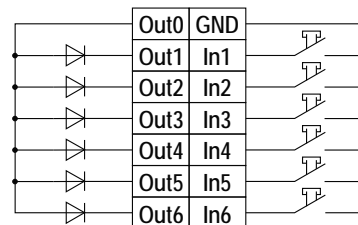
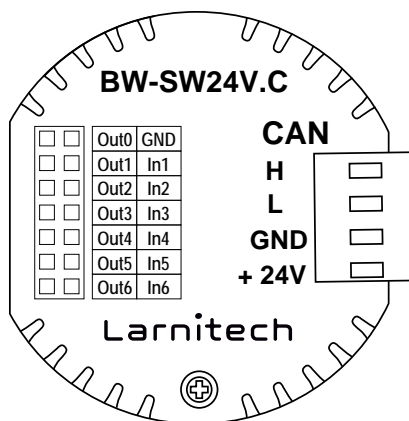

[TO CONTENTS](#)

BW-LSA LEAKAGE SENSOR ADAPTER

This module allows connecting two leakage sensors and has the function of detecting the presence of the sensor.



Module parameters

Parameter name	Value
Input channels qty	2
Power supply	11.5 ... 27.5 V DC from CAN
Max current(24V)	65 mA
Bus type	CAN (4-wire)
Compatible with	EW-WL FW-WL
Output voltage	8-14V
Output current	20 mA
Mounting	Free
Case material	ABS
Protection	IP40
Temperature range	-10 ... +50 °C
Size	45x42x14 mm
Weight	25 g

Connection example

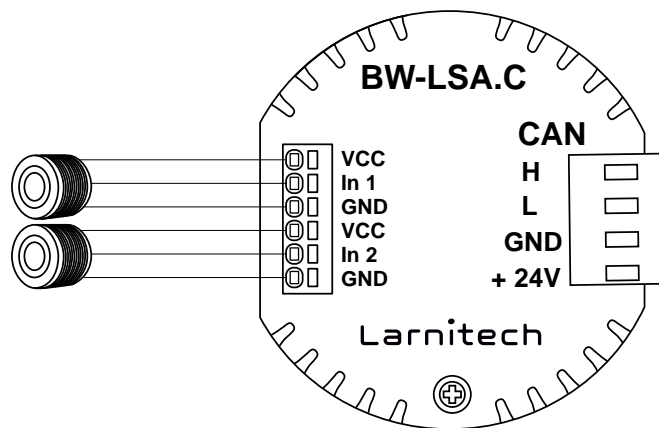

● Pattress box equipment ●

[TO CONTENTS](#)

BW-IO

6-CHANNEL I/O

MODULE

The module is designed for connection of other digital devices which do not have standard interfaces.



Module parameters

Parameter name	Value
Input channels qty	3
Output channels qty	3
Voltage that may be applied to the input channels	0...15 V DC
Min detected voltage threshold	2.5V
Max output switching voltage	60V AC/DC
Max output switching current	50mA
Power supply	11.5 ... 27.5 V DC from CAN
Max current(24V)	25 mA
Bus type	CAN (4-wire)
Mounting	Free
Case material	ABS
Protection	IP40
Temperature range	-10 ... +50 °C
Size	45x42x14 mm
Weight	15 g

Connection example

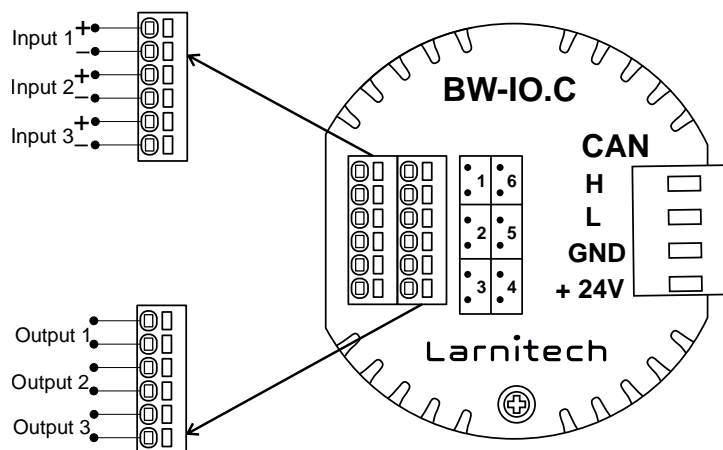

[TO CONTENTS](#)

BW-NA

NEST ADAPTER

This module is an adapter for connecting NEST thermostat (US version only) to the Smart Home system.



Module parameters

Parameter name	Value
Input channels qty	5
Output	24 V AC
Power supply	23 ... 25 V DC from CAN
Max current(24V)	70 mA
Bus type	CAN (4-wire)
Mounting	Free
Case material	ABS
Protection	IP40
Temperature range	-10 ... +50 °C
Size	45x42x14 mm
Weight	15 g

Connection example

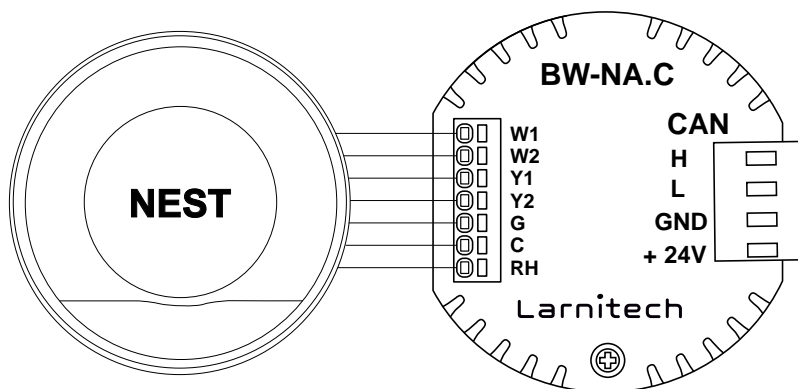

● Pattress box equipment ●

[TO CONTENTS](#)

BW-RS485

RS485 INTERFACE ADAPTER

This module is designed for interface adjustment between the devices which have the RS485 interface and the Smart Home system. The module has an internal 120Ω terminator resistor.

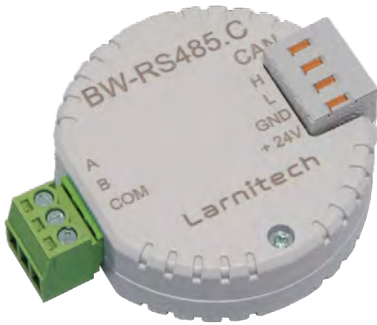

Module parameters

Parameter name	Value
RS485 port quantity	1
Power supply	11.5 ... 27.5 V DC from CAN
Max current(24V)	25 mA
Bus type	CAN (4-wire)
Mounting	Free
Case material	ABS
Protection	IP40
Temperature range	-10 ... +50 °C
Size	45x42x14 mm
Weight	15 g

FEATURES

- Supported protocols:
 - ModBus RTU
 - Custom protocols
- 1200 - 115200 baud rate

Connection example

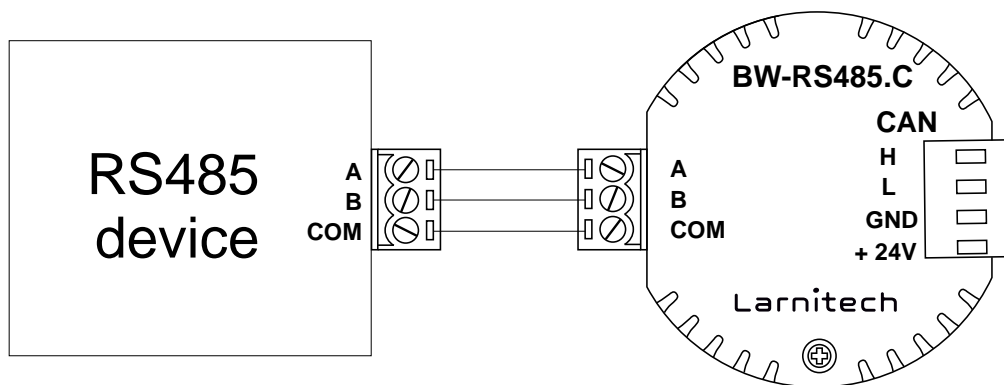

[TO CONTENTS](#)

BW-RS232

RS232 INTERFACE ADAPTER

This module is designed for interface adjustment between the devices which have the RS232 interface and the Smart Home system.



Module parameters

Parameter name	Value
RS232 port quantity	1
Power supply	11.5 ... 27.5 V DC from CAN
Max current(24V)	25 mA
Bus type	CAN (4-wire)
Mounting	Free
Case material	ABS
Protection	IP40
Temperature range	-10 ... +50 °C
Size	45x42x14 mm
Weight	15 g

Connection example

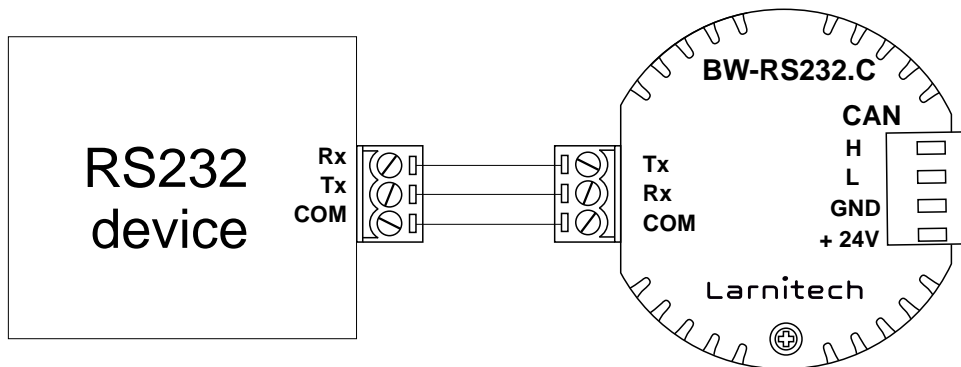

● Pattress box equipment ●

[TO CONTENTS](#)

BW-UART SERIAL PORT ADAPTER

This module is designed for interface adjustment between the devices which have the UART interface (TTL levels) and the Smart Home system.

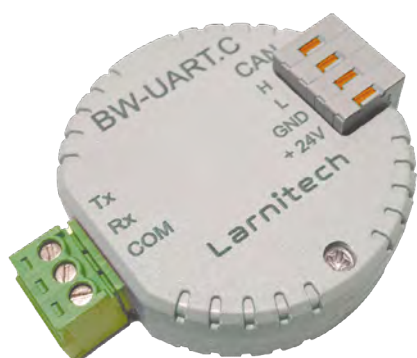

Module parameters

Parameter name	Value
UART port quantity	1
Power supply	11.5 ... 27.5 V DC from CAN
Max current(24V)	25 mA
Bus type	CAN (4-wire)
Mounting	Free
Case material	ABS
Protection	IP40
Temperature range	-10 ... +50 °C
Size	45x42x14 mm
Weight	15 g

Connection example

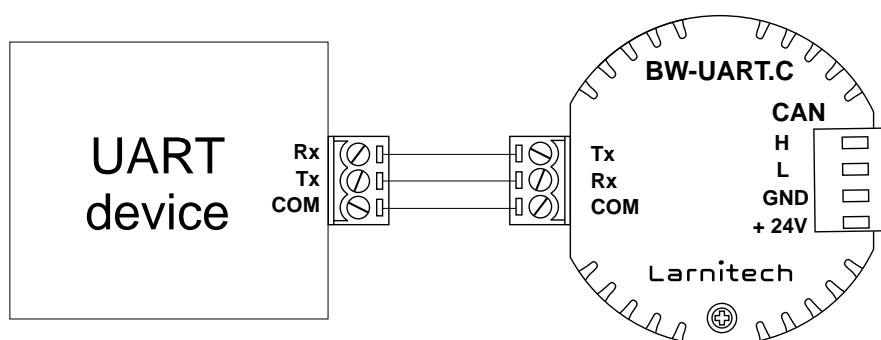

BW-010

4-CHANNEL MODULE FOR DEVICES WITH 0-10V INPUT

This module allows connecting devices with 0-10V input interface to the Smart Home system.



Module parameters

Parameter name	Value
0-10 input port quantity	2
0-10 output port quantity	4
Max load per channel	15mA
Power supply	11.5 ... 27.5 V DC from CAN
Max current(24V)	55 mA
Bus type	CAN (4-wire)
Mounting	Free
Case material	ABS
Protection	IP40
Temperature range	-10 ... +50 °C
Size	45x42x14 mm
Weight	15 g

Connection example

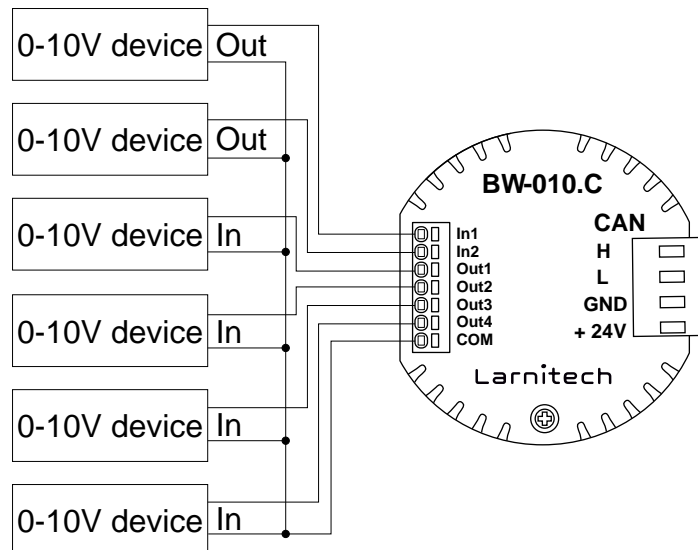

● Pattress box equipment ●

[TO CONTENTS](#)

BT-CAN

CAN to Bluetooth adapter

This module is used to connect to remote devices via Bluetooth.



Module parameters

Parameter name	Value
Power supply	11.5 ... 27.5 V DC from CAN or PS
Max current(24V)	30 mA
Max BT distance	220 m
Bus type	CAN (4-wire)
Equipment installation type	Free
Case material	ABS
Protection	IP40
Temperature range	-10 ... +50 °C
Size	45x42x14 mm
Weight	25 g

Connection example

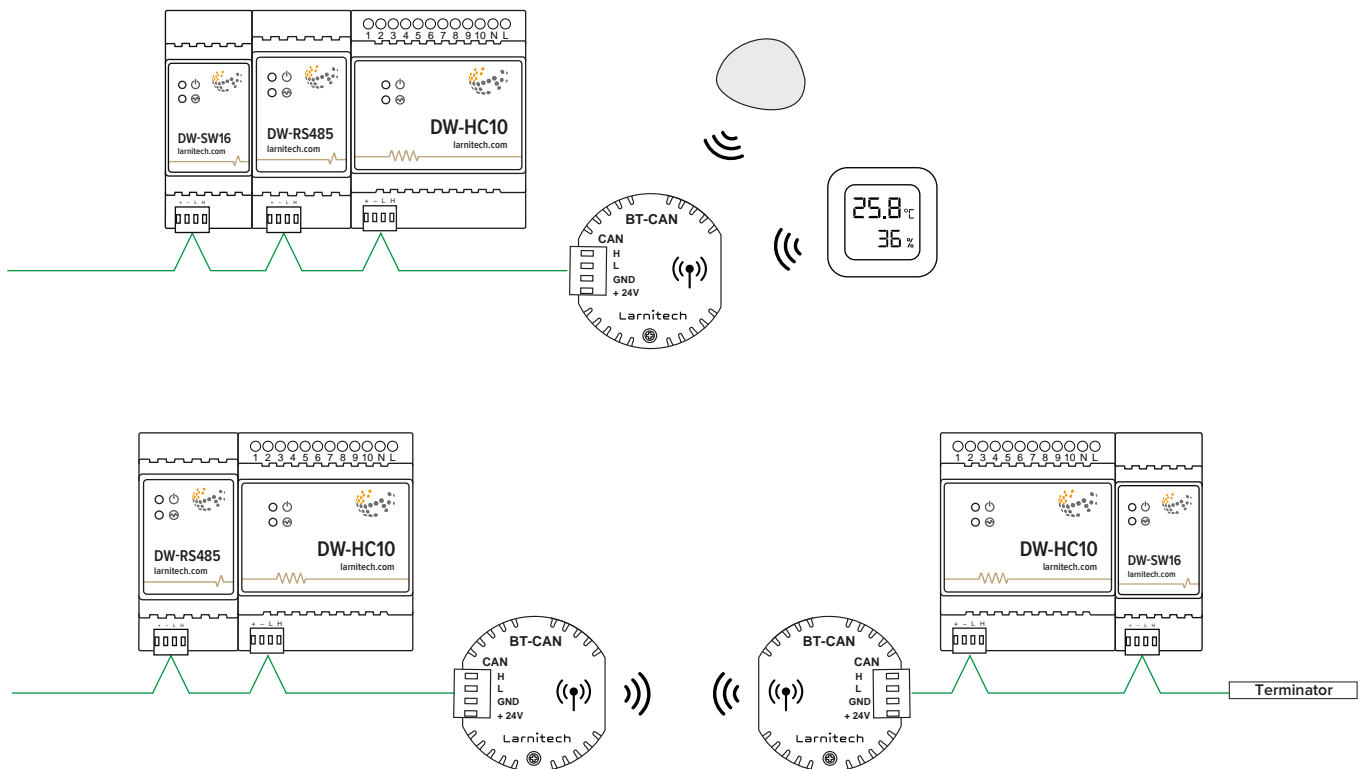

[TO CONTENTS](#)

SENSORS

[TO CONTENTS](#)



CW-AIR / CW-AIR(black) / CW-HTMLI-III

6 IN 1 SENSOR

This module contains motion, lighting, humidity, temperature, air quality sensor and an IR transmitter.

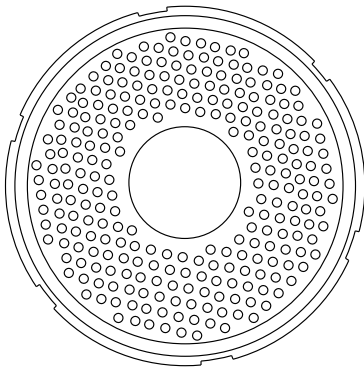
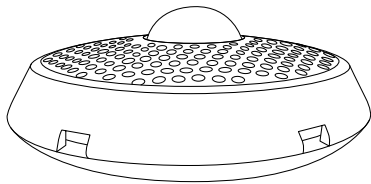

Module parameters

Parameter name	Value
Control parameters	Humidity, lighting, movement, temperature, air quality sensor
Angle of vision IR	360°
Power supply	11.5 ... 27.5 V DC from CAN
Max current(24V)	100 mA
Bus type	CAN (4-wire)
Equipment installation type	Wall, ceiling
Case material	ABS
Protection	IP40
Temperature range	-10 ... +50 °C
Size	85x85x35 mm
Weight	70g

CW-M-II / CW-M-II (black) / CW-MLI-II

MOTION SENSOR

This module contains motion sensor, lighting sensor, and an IR transmitter.

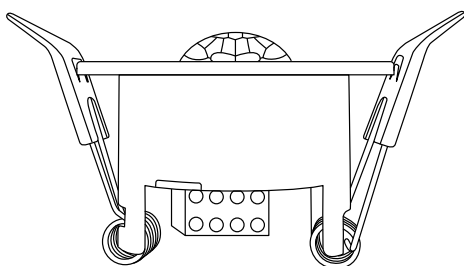
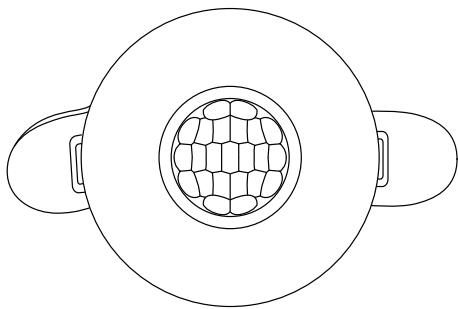

Module parameters

Parameter name	Value
Control parameters	Motion, Lightning (CW-MLI-II only)
Angle of vision IR	360° (CW-MLI-II only)
Max IR distance	3 meters* (CW-MLI-II only)
Power supply	11.5 ... 27.5 V DC from CAN
Max current(24V)	50 mA
Bus type	CAN (4-wire)
Equipment installation type	Cell
Case material	ABS
Protection	IP40
Temperature range	-10 ... +50 °C
Size	51x51x37 mm
Weight	25 g

* Depends on many factors, such as the sensitivity of the IR receiver, the reflectivity of surfaces etc. Recommended distance up to 3 meters

Module dimentions

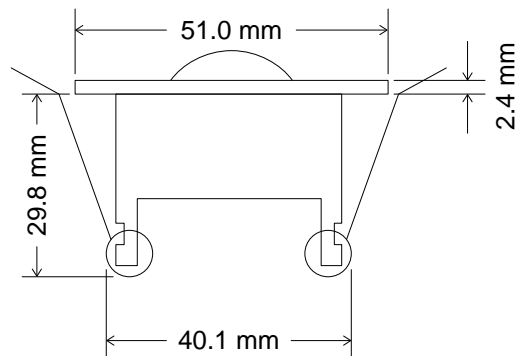

[TO CONTENTS](#)

CW-MLI / CW-M

MICRO-SIZED 3 IN 1 SENSOR

This module contains motion, lighting (CW-MLI only) sensors and an IR transmitter (CW-MLI only).



Module parameters

Parameter name	Value
Control parameters	Motion, lighting(optional)
Angle of vision IR	360°
Power supply	11.5 ... 27.5 V DC from CAN
Max current(24V)	50 mA
Max IR distance	3 meters*
Bus type	CAN (4-wire)
Mounting	Cell
Protection	IP40
Temperature range	-10 ... +50 °C
Size	17x17x60 mm
Weight	15 g

* Depends on many factors, such as the sensitivity of the IR receiver, the reflectivity of surfaces etc. Recommended distance up to 3 meters

Connection example

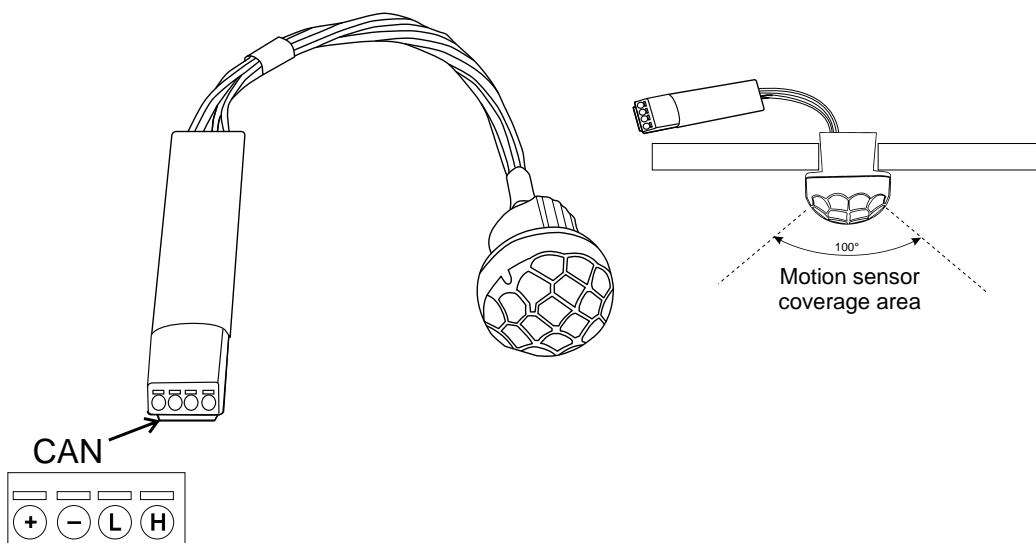

[TO CONTENTS](#)

CW-MSD

MICRO-SIZED MOTION SENSOR

Motion sensor which can be connected to the Metafora series modules.

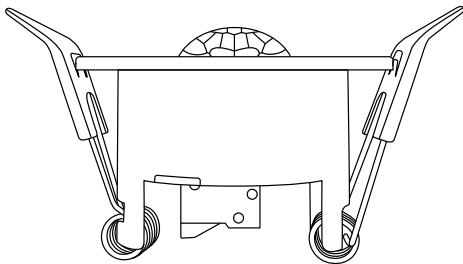
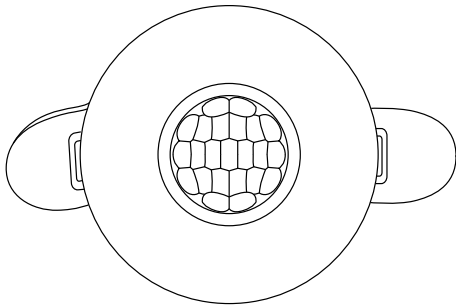

Module parameters

Parameter name	Value
Control parameters	Motion
Angle of motion	100°
Power supply	5 ... 13 V DC
Max current(13V)	1 mA
Max detection distance	10m
Bus type	CAN (4-wire)
Compatible with	Metafora series devices
Equipment installation type	Cell
Case material	ABS
Protection	IP40
Temperature range	-10 ... +50 °C
Size	51x51x37 mm
Weight	15 g

Module dimentions

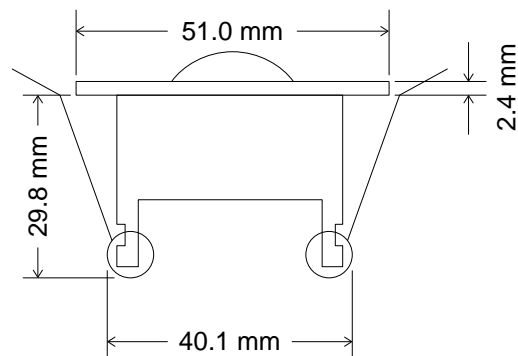

WW-HTL 3 IN 1 SENSOR

This module contains temperature, lighting, and humidity sensors.

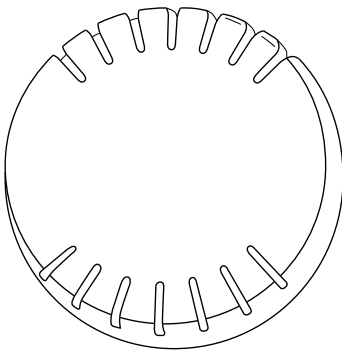

Module parameters

Parameter name	Value
Control parameters	Temperature, humidity, lighting
Temperature measuring range	-10 ... +50°C
Humidity measuring range	0 ... 100%
Power supply	11.5 ... 27.5 V DC from CAN
Max current(24V)	25 mA
Bus type	CAN (4-wire)
Mounting	Wall, ceiling
Case material	ABS
Protection	IP40
Size	40x40x12
Weight	50 g

WW-TS

TEMPERATURE SENSOR

It is a temperature sensor for DW-HCxx module.

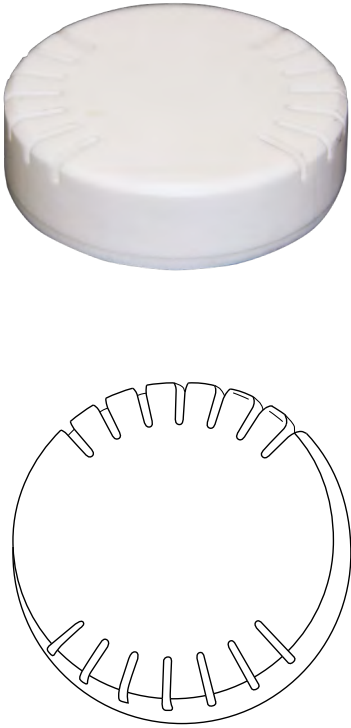

Module parameters

Parameter name	Value
Control parameters	Temperature
Temperature measuring range	-20 ... +60°C
Power supply	5 V DC
Max current	5 mA
Bus type	One Wire
Compatible with	DW-HCxx BW-LC/DM/SW DW-HT07 Metafora devices
Mounting	Wall
Case material	ABS
Protection	IP40
Size	40x40x12 mm
Weight	35 g

Connection example

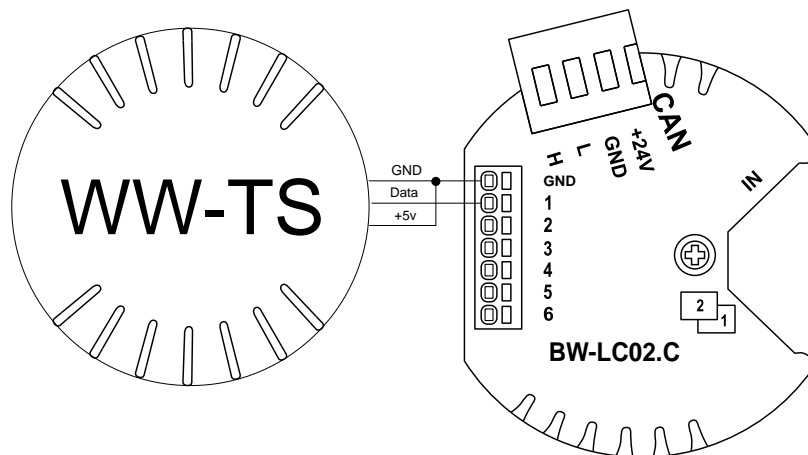

FW-TS

TEMPERATURE SENSOR

This is an open-frame temperature sensor for DW-HCxx module.

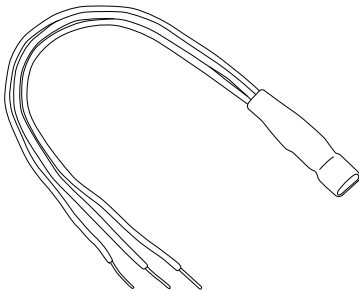
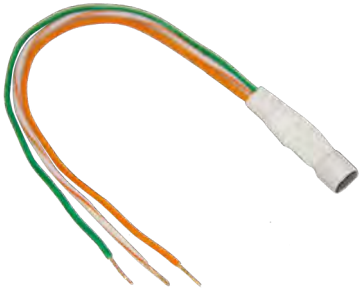

Module parameters

Parameter name	Value
Control parameters	Temperature
Temperature measuring range	-20 ... +60°C
Power supply	5 V DC
Max current	5 mA
Bus type	One Wire
Compatible with	DW-HCxx BW-LC/DM/SW DW-HT07 Metafora devices
Mounting	Free
Protection	IP40
Size	5x4x8 mm
Weight	15 g

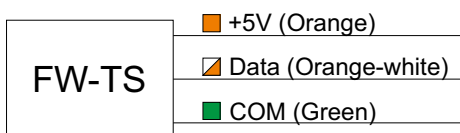

Connection example

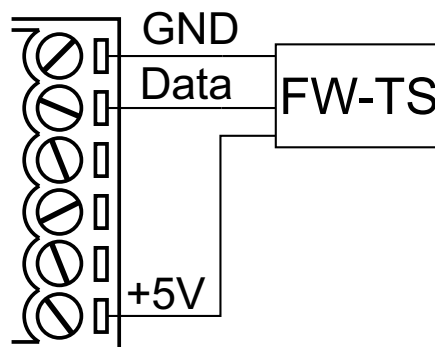

[TO CONTENTS](#)

FW-FT

UNDERFLOOR HEATING TEMPERATURE SENSOR

This is an underfloor heating temperature sensor for DW-HCxx, it can also be used to measure the outdoor temperature.

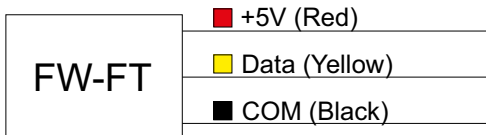
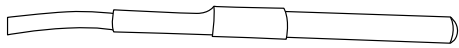

Module parameters

Parameter name	Value
Control parameters	Temperature
Temperature measuring range	-20 ... +60°C
Power supply	5 V DC
Max current	5 mA
Bus type	One Wire
Compatible with	DW-HCxx BW-LC/DM/SW DW-HT07 Metafora devices
Mounting	Built into the floor/outdoor
Sensor cable length	3 m
Sensor line max length	30 m*
Protection	IP65
Size	8x8x50 mm
Weight	35 g

Connection example

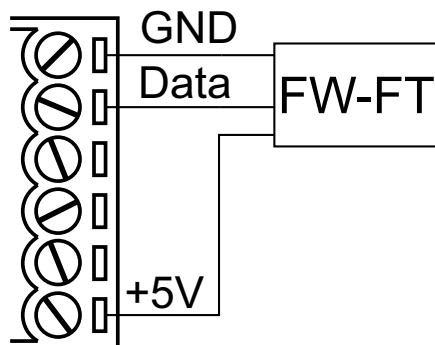

[TO CONTENTS](#)

EW-WL

BUILT-IN FLOOR LEAKAGE SENSOR

This is a water leakage sensor with an alarm light. It is mountable in the floor surface. Used together with DW-WL or BW-LSA modules.

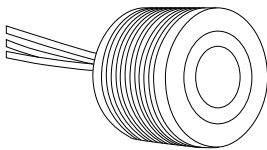

FEATURES

- Sensor presence detection
- Customizing the indication colors
- Adjusting the sensor sensitivity
- Connections of several sensors to one bus

Module parameters

Parameter name	Value
Power supply	9...12 V DC
Max current	20 mA
Compatible with	Metafora devices Metafora cloud devices DW-WL02/HTxx BW-LSA
Mounting	Built into the floor
Case material	stainless steel
Protection	IP65
Temperature range	-10 ... +50 °C
Size	18x18x20 mm
Weight	20 g

EW-WL

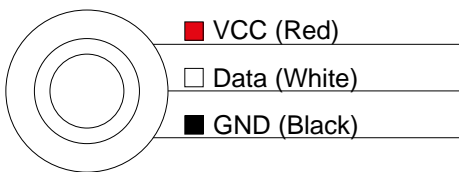

Connection example

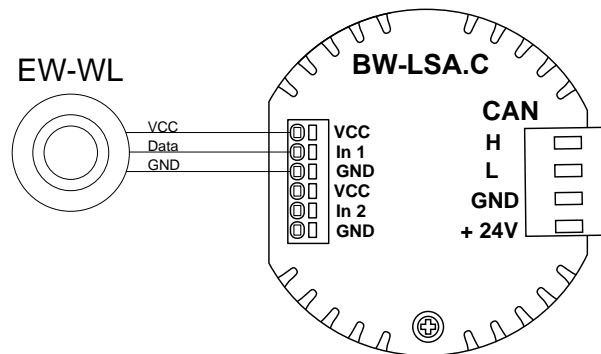

[TO CONTENTS](#)

FW-WL ON-THE-FLOOR LEAKAGE SENSOR

The sensor is placed on the floor surface. It has an alarm light, which changes from green to red if the sensor detects water on the floor. Used together with DW-WL02 or BW-LSA modules.

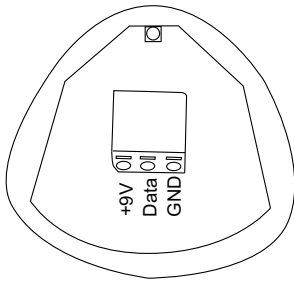

Module parameters

Parameter name	Value
Power supply	9...12 V DC
Max current	20 mA
Compatible with	Metafora devices Metafora cloud devices DW-WL02/HTxx BW-LSA
Mounting	Free
Case material	ABS
Protection	IP64
Temperature range	-10 ... +50 °C
Size	57x47x22 mm
Weight	35 g

FEATURES

- Sensor presence detection
- Customizing the indication colors
- Adjusting the sensor sensitivity
- Connections of several sensors to one bus

Connection example

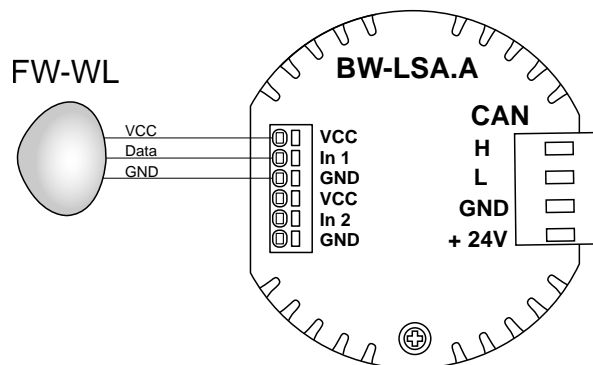

[TO CONTENTS](#)

FW-WLM / FW-WLM(black) ON-THE-FLOOR LEAKAGE SENSOR

The sensor is placed on the floor surface. Used together with DW-WL02 or BW-LSA modules.

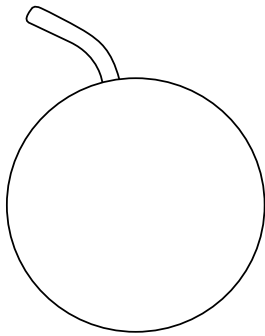

Module parameters

Parameter name	Value
Power supply	9-12 V DC
Max current(24V)	20 mA
Compatible with	Metafora devices DW-WL02/HTxx BW-LSA RC12
Equipment installation type	Free
Case material	Metal
Protection	IP64
Temperature range	-10 ... +50 °C
Size	57x47x22 mm
Weight	35g

Connection example

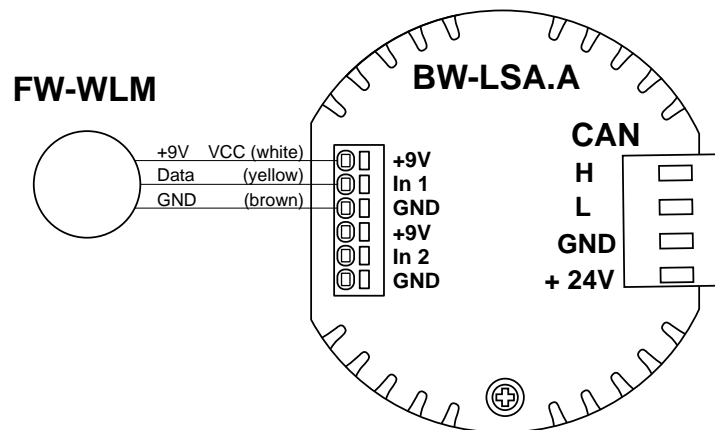

[TO CONTENTS](#)

WW-WL WALL LEAKAGE SENSOR

The sensor is placed on the wall. Used together with DW-WL02 or BW-LSA modules.

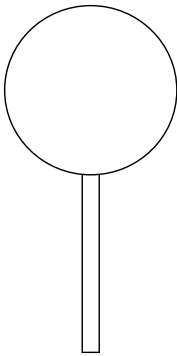

Module parameters

Parameter name	Value
Power supply	9-12 V DC
Max current(24V)	20 mA
Compatible with	Metafora devices DW-WL02/HTxx BW-LSA
Equipment installation type	Free
Case material	ABS
Protection	IP64
Temperature range	-10 ... +50 °C
Size	57x47x22 mm
Weight	35g

FEATURES

- Sensor presence detection
- Adjusting the sensor sensitivity
- Connections of several sensors to one bus

Connection example

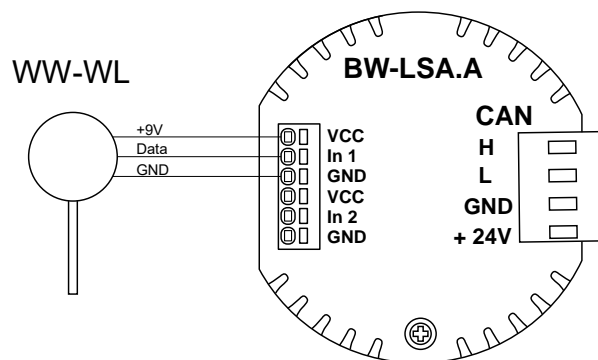

BT-HT

This is a sensor that works with our BT-CAN bluetooth module. The sensor shows the temperature and humidity.



Module parameters

Parameter name	Value
Power supply	DC 2.5V - 3V
Case material	ABS
Connection type	Bluetooth 4.2
Temperature range	0°C - 60°C
Humidity range	0% - 99% RH
Size	43x43x12,5mm
Weight	21g

MULTIROOM

[TO CONTENTS](#)



FE-MP MEDIA POINT

Multiroom system media point with a built-in amplifier. Used to play music, the Internet radio, system notifications. Supports DLNA protocol. Can be used either within the Smart Home system or separately.

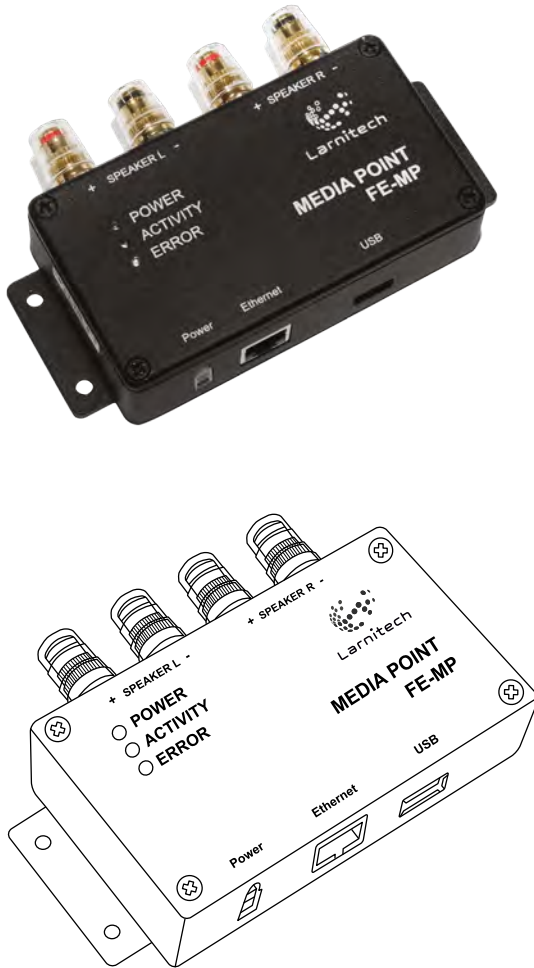

Module parameters

Parameter name	Value
Analog outout channels qty	2
Speakers	4-8 ohm
Max power output audio channel	2x20W
Connection type	Ethernet
Transfer data speed	10/100 MB/s
Power supply	23...26V DC
Max current(24V)	3.3 A, 24V 4.2 A Recommended
Case material	Aluminium
Protection	IP40
Mounting type	Free
Temperature range	-10...+50 °C
Dimensions	140x64x30 mm
Weight	500 g

FE-IC.nfc

VIDEO INTERCOM

Video intercom calling panel. It has a built-in NFC reader, a HD camera with IR illumination and a relay for connecting the electric lock. It also has a built-in memory for taking photos or recording videos. Supports SIP and DLNA protocols.

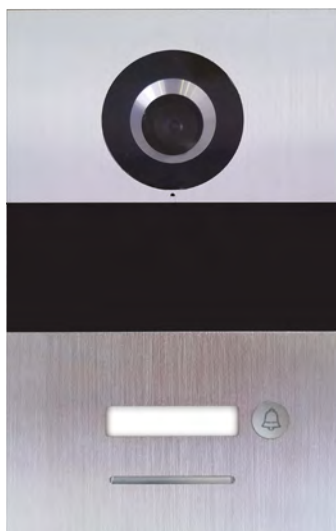

Module parameters

Parameter name	Value
Camera	Full HD (1920×1080)
Card reader	RFID 125kHz NFC tag Android devices with NFC
IR lighting	1 m
Connection type	Ethernet
Protocols	SIP, DLNA
Power supply	PoE (802.3af), Passive POE 24V
Max current(24V)	150 mA
Case material	Aluminium alloy panel
Protection	IP65
Mounting type	Wall surface mount
Temperature range	-20...+35 °C
Dimensions	194x120x45 mm
Weight	950 g

LCP10

WALL-MOUNTED CONTROL PANEL

Wall-mounted control panel.

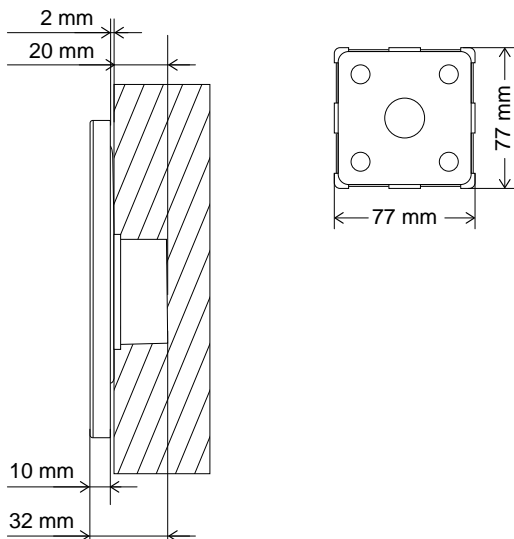
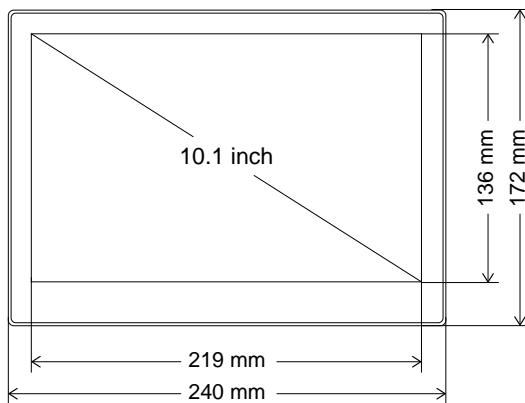

Tablet parameters

Parameter name	Value
CPU	RK3566 Quad-Core ARM Cortex-A55 1.8GHz
RAM	2G
Internal memory	32G
Operation System	Android 11
Display	10.1" inch Touch IPS Touch Screen
Panel	Full HD 10.1" LCD panel
Resolution	1280*800
Luminance	500cdm2
Aspect Ratio	16:9
WiFi	802.11b/g/n
Ethernet	10M/100M Ethernet
Bluetooth	4.0
USB Device	Type C
Power Jack	DC power 12V
Ethernet POE	802.3af
Material	Metal Case
Speaker	2W*2
Weight	1.5kg
Language	Multi-language

LCP4

WALL-MOUNTED CONTROL PANEL

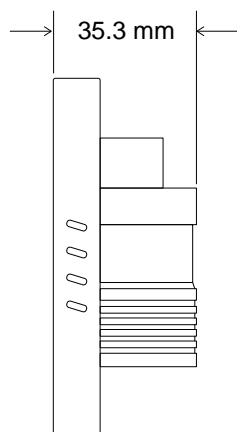
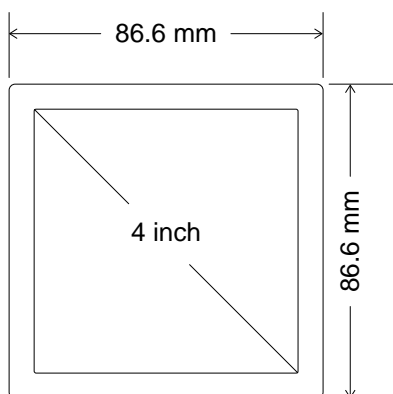

Module parameters

Parameter name	Value
Dimension	86.6mm*86.6mm*35.3mm
Display size	4 inch
CPU	Quad-core cortex-A7 ,1.2Ghz
System	Android 7.1
Resolution	480*480
Touch Panel	5 points capacitive touch panel, IPS
RAM	1G
Rom	8G
WIFI	802.11b/g/n
Bluetooth	BT 4.0
Ethernet	10M/100M
RJ45	Ethernet interface input (RJ-45 cable)
Power suply	AC 110~240V , 50HZ
Microphone	build in
Camera	No camera
Battery	NO
Mount	wall mounted / in wall & embedded
Color	Black
Power consumption	20W
Physical button	Power on/ off
Working temperature	-5..70°C
Language	Multi-language

OTHER EQUIPMENT

[TO CONTENTS](#)



WW-TERM THERMOSTAT

The thermostat module is designed for controlling temperature in the room via fancoils. The device is equipped with 4 buttons to control the settings of climate



Module parameters

Parameter name	Value
Output channels qty	4 (fancoils only)
Power requirement	11.5 ... 27.5 V DC from CAN
Power consumption	<1W
Protocol	CAN-BUS
Operational temperature	-10 to +70 °C
Humidity	5% to 90% non-condensing
Material	Aluminum
Face plate dimension	86x86mm
Max power output rate	1000W
Total Load (With Neutral)	1800W Res
Digital inputs	1 input (temperature-sensor)
Digital outputs	IR transmitter
Weight	200 g

Connection example

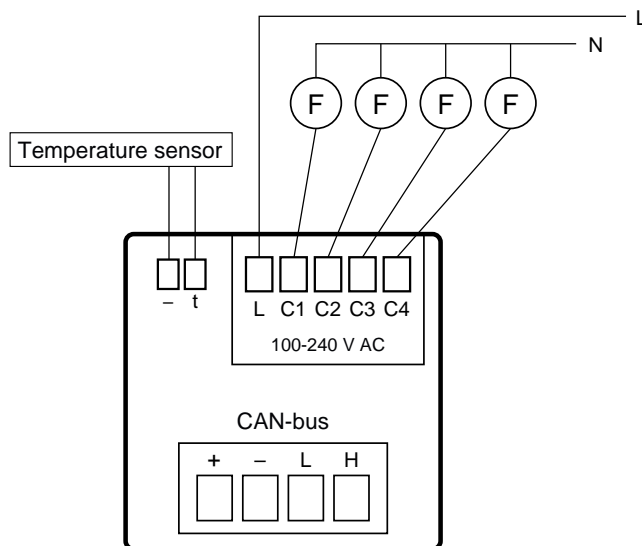

Other equipment

[TO CONTENTS](#)

WW-BTN LIGHT SWITCH

The light switch is an intelligent device that can be controlled through a CAN-BUS network. The limitation of nodes (CAN-BUS products) is about 110 units per bus. This switch can be used to control 4 fancoils and linking buttons. You can assign the internal relay to any touch buttons (short or long-press).



Module parameters

Parameter name	Value
Output channels qty	4 (fancoils only)
Power requirement	11.5 ... 27.5 V DC from CAN
Power consumption	<1W
Protocol	CAN-BUS
Operational temperature	-10 to +70 °C
Humidity	5% to 90% non-condensing
Material	Aluminum
Face plate dimension	86x86mm
Max power output rate	1000W
Total Load (With Neutral)	1800W Res
Digital inputs	1 input (temperature-sensor)
Weight	200 g

Connection example

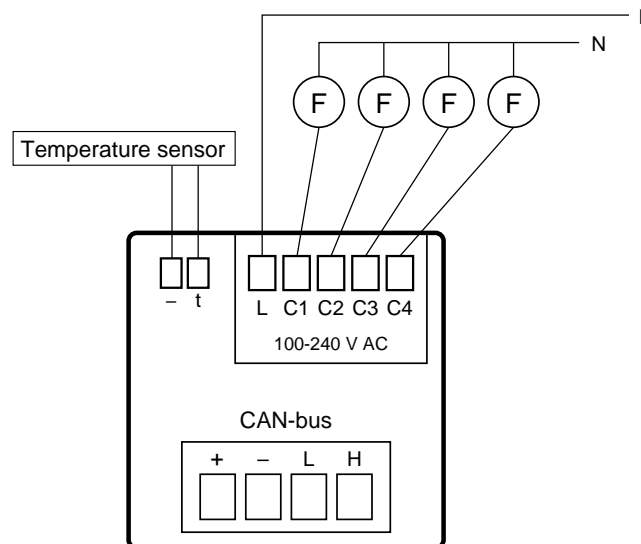

[TO CONTENTS](#)

LED-DRV

4-CHANNEL LED DRIVER

This module allows interpretation of controlling signals from IO connections for 12/24V LED/RGB strips.



Module parameters

Parameter name	Value
Output channels qty	4
Input voltage	5V
Output voltage	12-24 V DC
Current type	DC
Adjustment type	PWM
Max load per channel	3A
Power supply	11.5 ... 27.5 V DC
Equipment installation type	Free
Case material	Aluminum
Protection	IP40
Temperature range	-10 ... +50 °C
Size	65x18x15 mm
Weight	25 g

Connection example

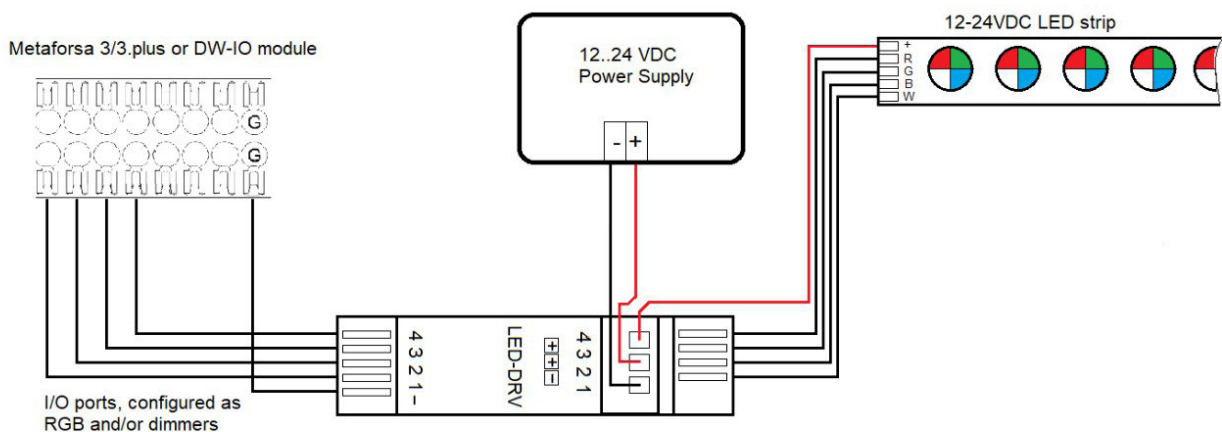

Other equipment

[TO CONTENTS](#)

LED-AMP

4-CHANNEL LED AMPLIFIER

LED-AMP is a simple amplifier that works on the principle of input=output. It is designed for use with LED strips or other LED light devices.



Module parameters

Parameter name	Value
Output channels qty	4
Input voltage	11.5 ... 25V
Output voltage	12-24 V DC
Current type	DC
Adjustment type	PWM
Max load per channel	3A
Power supply	11.5 ... 27.5 V DC
Equipment installation type	Free
Case material	Aluminum
Protection	IP40
Temperature range	-10 ... +50 °C
Size	65x18x15 mm
Weight	25 g

Connection example

